

Wireless Sounder / Visual Indicator Installation Guide

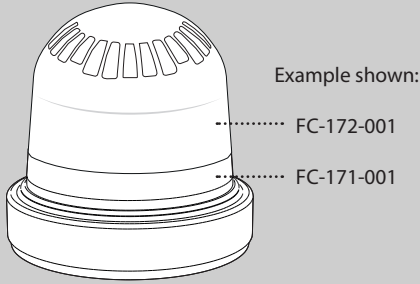

Part no	Description	CPR
FC-171-001	White Wireless Sounder Base Only	[2]
FC-171-002	Red Wireless Sounder Base Only	[2]
FC-172-001	White Sounder Only	[1]
FC-172-002	Red Sounder Only	[1]
FC-173-002	Red Sounder Visual Indicator Only	[1]
FC-173-003	Amber Sounder Visual Indicator Only	[1]
FC-173-004	Clear Sounder Visual Indicator Only	[1]
FC-178-002	Red Visual Indicator Only	[1]
FC-178-003	Amber Visual Indicator Only	[1]
FC-178-004	Clear Visual Indicator Only	[1]

See the Specification section for compliance information.

1 Pre installation

! Installation must conform to applicable local installation codes and should only be installed by a fully trained competent person.

- Ensure that the device is installed as per the site survey.
- The use of a non-metallic spacer should be considered if mounting the device on to a metal surface.
- Do NOT Press the Log On button on a pre-programmed device, as this will cause communication with the Control Panel to be lost. Should this happen, delete the device from the system and add it back on.
- This device contains electronics that may be susceptible to damage from Electrostatic Discharge (ESD). Take appropriate precautions when handling electronic boards.

2 Components

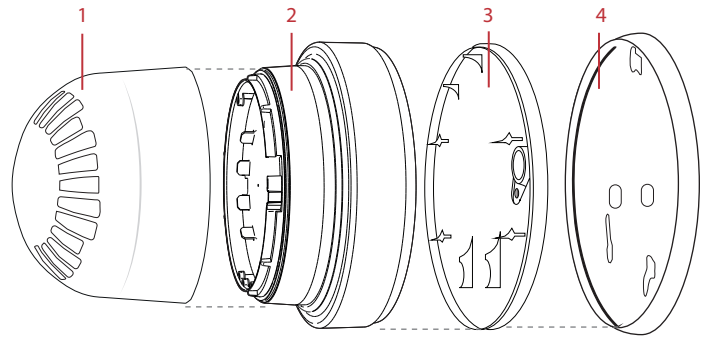

1 Sounder / visual indicator, 2 Wireless module, 3 Battery retaining plate, 4 Mounting plate

3 Fix mounting plate

Remove the mounting plate by turning the device **ANTICLOCKWISE**, to release it from the mounting plate.

- Use both fixing positions to ensure a firm fixing.
- Use suitable fasteners and fixings.

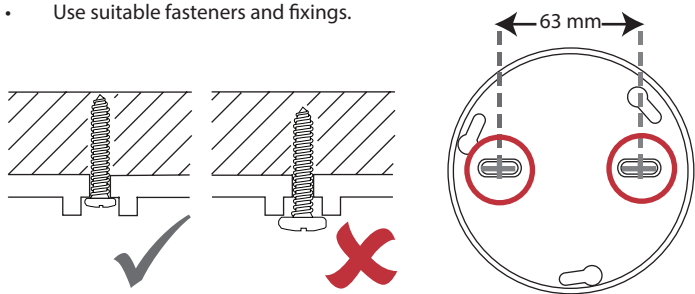

4 Power device

- Unclip the battery retaining plate from the wireless module.
- When fitting / replacing batteries; observe correct polarity, using only specified batteries.
- Connect the power jumper across the PIN header.

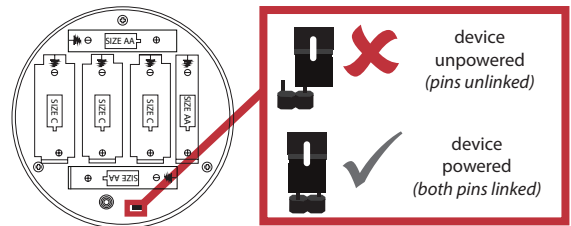

- Once powered, reassemble the device.

5 Optional device locking

- To lock the sounder / visual indicator into the wireless module, remove the cut out section as shown.

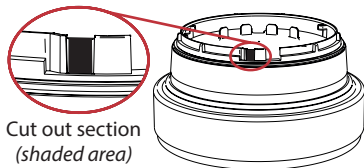

Cut out section (shaded area)

- To unlock the device, insert a 1.5 mm allen key to depress the locking clip and turn anticlockwise to release.

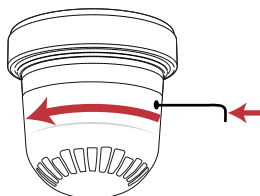

6 Configuration

The device's loop address is configured within the user interface's menu structure.

- Refer to the programming manual for full programming details.

FireCell = MK98
Fusion = TSD062
WZM = TSD143

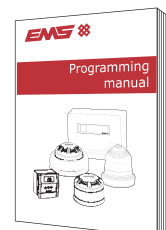

Free to download from
www.ems-group.co.uk

Configuration continued

Sounder tone (set on sounder/visual indicator)

The 5 way switch is used to configure the sounder tone.

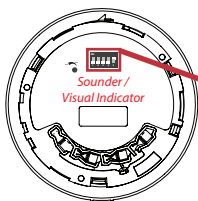

All 32 available configurations are shown in the tone table.

Default setting: primary tone 5

Volume (set on sounder/visual indicator)

The sound output of the unit can also be reduced by adjusting the potentiometer as shown.

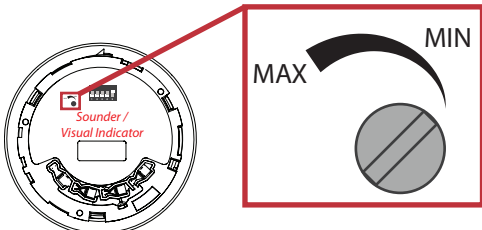

Default setting: high volume

Audio monitoring (set on wireless module)

The primary and secondary stage sounder tones can be monitored. If enabled and no audio is detected within 10 seconds upon sounder activation, a fault is indicated at the control panel.

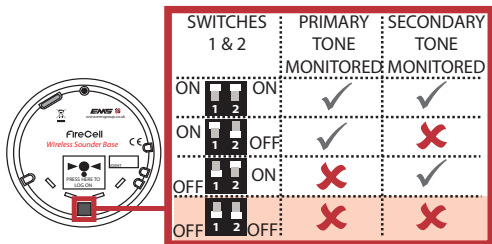

Default setting: audio monitoring disabled

SWITCHES 1 TO 5	PRIMARY TONE	TONE TYPE	TONE DESCRIPTION / APPLICATION	SECONDARY TONE
ON 1 2 3 4 5	1	— — — —	970Hz	8
ON 1 2 3 4 5	2	□ □ □ □	800Hz/970Hz at 2Hz	1
ON 1 2 3 4 5	3	∩ ∩ ∩ ∩	800Hz - 970Hz at 1Hz	1
ON 1 2 3 4 5	4	- - - -	970Hz 1s OFF / 1s ON	1
ON 1 2 3 4 5	5	□ □ □ □	970Hz, 0.5s / 630Hz, 0.5s	4
ON 1 2 3 4 5	6	□ □ □ □	554Hz, 0.1s / 440Hz, 0.4s (AFNOR NFS 32 001)	1
ON 1 2 3 4 5	7	∩ ∩ ∩ ∩	500 - 1200Hz, 3.5s / 0.5s OFF (NEN 2575:2000)	1
ON 1 2 3 4 5	8	- - - -	420Hz 0.625s ON / 0.625s OFF (Australia AS1670 Alert tone)	9
ON 1 2 3 4 5	9	∩ ∩ ∩ ∩	500 - 1200Hz, 0.5s / 0.5s OFF x 3 / 1.5s OFF (AS1670 Evacuation)	1
ON 1 2 3 4 5	10	□ □ □ □	550Hz / 440Hz at 0.5Hz	19
ON 1 2 3 4 5	11	- - - -	970Hz, 0.5 ON / 0.5s OFF x 3 / 1.5s OFF (ISO 8201)	1
ON 1 2 3 4 5	12	- - - -	2850Hz, 0.5s ON / 0.5s OFF x 3 / 1.5s OFF (ISO 8201)	1
ON 1 2 3 4 5	13	∩ ∩ ∩ ∩	1200Hz - 500Hz at 1Hz (DIN 33 404)	1
ON 1 2 3 4 5	14	— — — —	400Hz	18
ON 1 2 3 4 5	15	□ □ □ □	550Hz, 0.7s / 1000Hz, 0.33s	1
ON 1 2 3 4 5	16	∩ ∩ ∩ ∩	1500Hz - 2700Hz at 3Hz	1
ON 1 2 3 4 5	17	— — — —	750Hz	1
ON 1 2 3 4 5	18	— — — —	2400Hz	1
ON 1 2 3 4 5	19	— — — —	660Hz	18
ON 1 2 3 4 5	20	- - - -	660Hz 1.8s ON / 1.8s OFF	19
ON 1 2 3 4 5	21	- - - -	660Hz 0.15s ON / 0.15s OFF	19
ON 1 2 3 4 5	22	□ □ □ □	510Hz, 0.25s / 610Hz, 0.25s	1
ON 1 2 3 4 5	23	□ □ □ □	800 / 100Hz 0.5s each (1Hz)	1
ON 1 2 3 4 5	24	∩ ∩ ∩ ∩	250Hz - 1200Hz at 12Hz	1
ON 1 2 3 4 5	25	∩ ∩ ∩ ∩	500Hz - 1200Hz at 0.33Hz	1
ON 1 2 3 4 5	26	∩ ∩ ∩ ∩	2400Hz - 2900Hz at 9Hz	18
ON 1 2 3 4 5	27	∩ ∩ ∩ ∩	2400Hz - 2900Hz at 3Hz	18
ON 1 2 3 4 5	28	∩ ∩ ∩ ∩	800Hz - 970Hz at 100Hz	1
ON 1 2 3 4 5	29	∩ ∩ ∩ ∩	800Hz - 970Hz at 9Hz	1
ON 1 2 3 4 5	30	∩ ∩ ∩ ∩	800Hz - 970Hz at 3Hz	1
ON 1 2 3 4 5	31	- - - -	800Hz, 0.25s ON / 1s OFF	1
ON 1 2 3 4 5	32	∩ ∩ ∩ ∩	500Hz - 1200Hz, 3.75s / 0.25s OFF (AS2220)	8

Specification

Operating temperature	-10 to +55 °C
Storage temperature	5 to 30 °C
Humidity	0 to 95% non-condensing
Supply	3x AA Alkaline (Panasonic LR6AD Powerline / Varta 4006 Industrial) 3x C Alkaline (Panasonic LR14AD Powerline / Varta 4014 Industrial)
CAUTION!	Fitting of an incorrect battery type invalidates the product certification and may result in poor performance.
Sounder output	99 dBA at 1 m (as dispatched)
IP rating	IP54
Operating frequency	868 MHz
Output transmitter power	Auto adjusting 0 to 14 dBm (0 to 25 mW)
Signalling protocol	X
Dimensions (Ø x D)	120 x 125 mm
Weight	0.65 kg
Location	Type A: For indoor use

Regulatory Information

Manufacturer	KGS Manufacturing Poland Sp. z o.o. Ul. Kolejowa 24. 39-100 Ropczyce, Poland
Year of manufacture	See devices serial number label
Certification	
DoP number	See part listing for associated products: [1]0359-CPR-0022, [2]0359-CPR-0040
Approved to	See part listing for associated products: EN54-3:2001. Incorporating Amendments Nos. 1 and 2. Fire detection and fire alarm systems. Part 3: Fire alarm devices - Sounders. [1] EN54-25:2008. Incorporating corrigenda September 2010 and March 2012. Fire detection and fire alarm systems. Part 25: Components using radio links. [2]
European Union Directives	EMS declares that this device is in compliance with Directive 2014/53/EU. The full text of the EU declaration of conformity is available at the following internet address: www.emsgroup.co.uk
	2012/19/EU (WEEE directive): Products marked with this symbol cannot be disposed of as unsorted municipal waste in the European Union. For proper recycling, return this product to your local supplier upon purchase of equivalent new equipment, or dispose of it at designated collection points. For more information see www.recyclethis.info
	Dispose of your batteries in an environmentally friendly manner according to your local regulations.