

SmartCell

Wireless zone monitor

Product Showcase



Contents

- 3 | What is SmartCell WZM?
- 3 | Typical applications
- 4 | Addressable system connection
- 5 | Conventional system connection
- 6 | WZM benefits
- 6 | Wireless devices packed with features
- 7 | WZMs
- 8 | Detection
- 9 | Sounders
- 10 | Ceiling beacons
- 11 | Wall beacons
- 12 | Call point
- 12 | I/O unit
- 13 | Door controllers
- 14 | Batteries
- 15 | Spares
- 17 | Carriage

What is SmartCell WZM?

SmartCell Wireless Zone Monitor (WZM) provides universal connections to new and existing fire alarm control panels, and facilitates up to 16 third party EU certified SmartCell wireless fire devices. With maximum flexibility in mind, the SmartCell WZM connects to both conventional and addressable fire alarm systems. Wireless communication between the WZM and the wireless devices is fast, robust and bidirectional, utilising the European harmonised 868 MHz frequency band.

The SmartCell WZM is the quick, easy and universal method of fire system extension.

SmartCell, the future of fire detection available now.

Typical applications

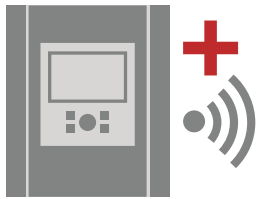

EXTENDING COVERAGE ON
EXISTING SYSTEMS

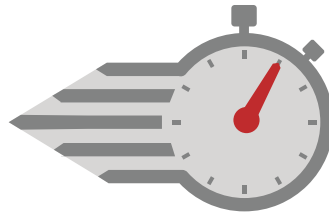

METHOD OF ACHIEVING
RAPID INSTALLATIONS



PROVIDING COVERAGE IN
REMOTE BUILDINGS



TROUBLEFREE ALTERNATIVE TO
POWER HUNGRY DEVICES



ADDING DETECTION IN
AREAS WITH ASBESTOS



GREAT WAY OF PROTECTING
HARD TO ACCESS AREAS

Addressable system connection*

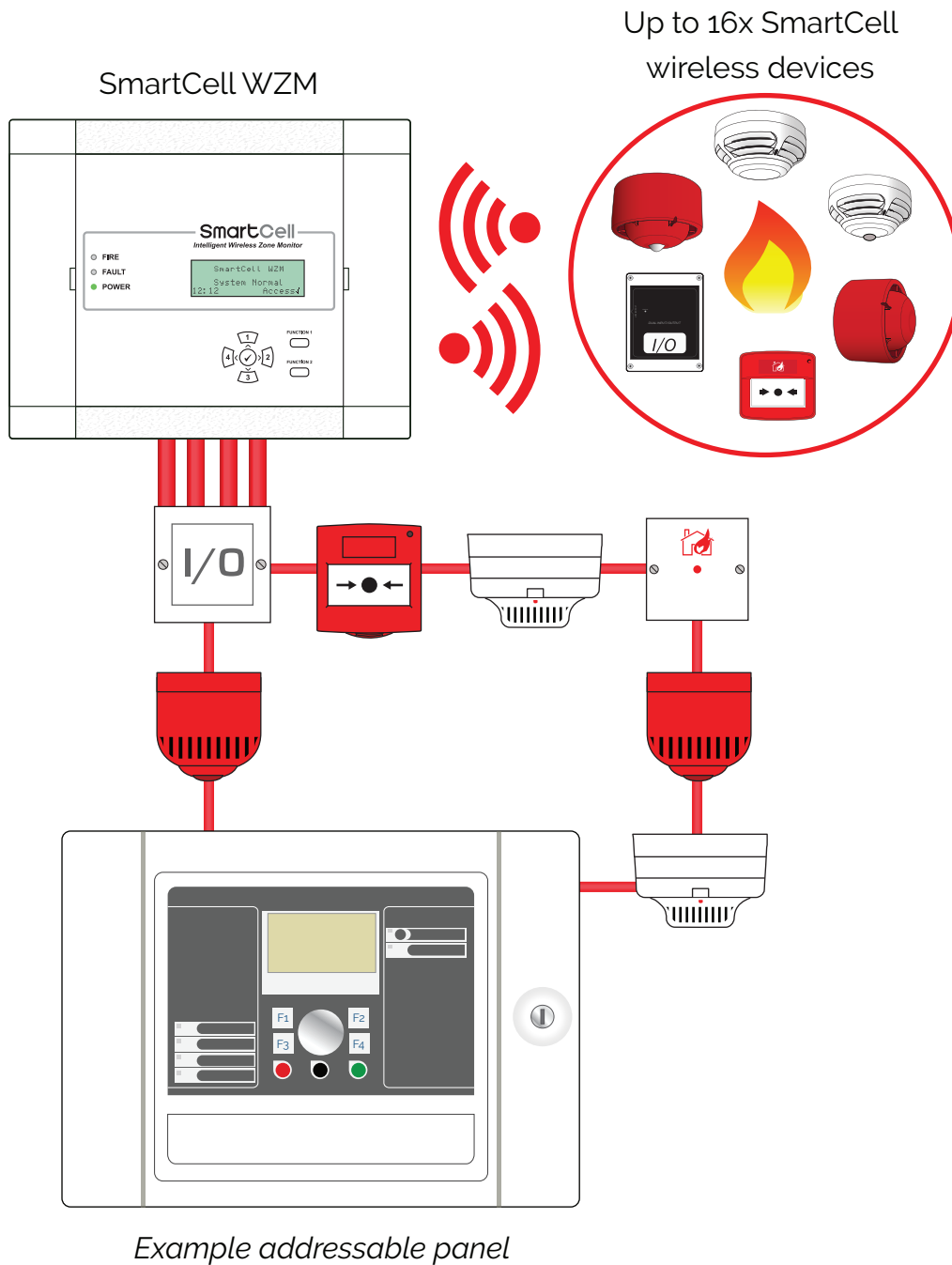

* The addressable system connection example illustrates a typical connection to the system via a 3rd party hardwired input/output device. Connection to an addressable system can be made either via the hardwired inputs and outputs of the hardwired addressable input/output device, or directly to the hardwired inputs and outputs of the panel.

Conventional system connection

Up to 16x SmartCell
wireless devices



SmartCell WZM

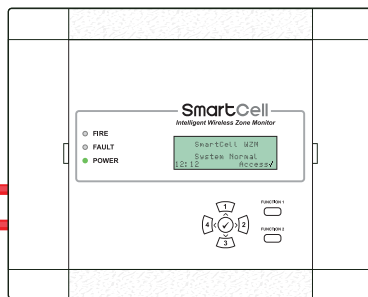

Example Conventional panel

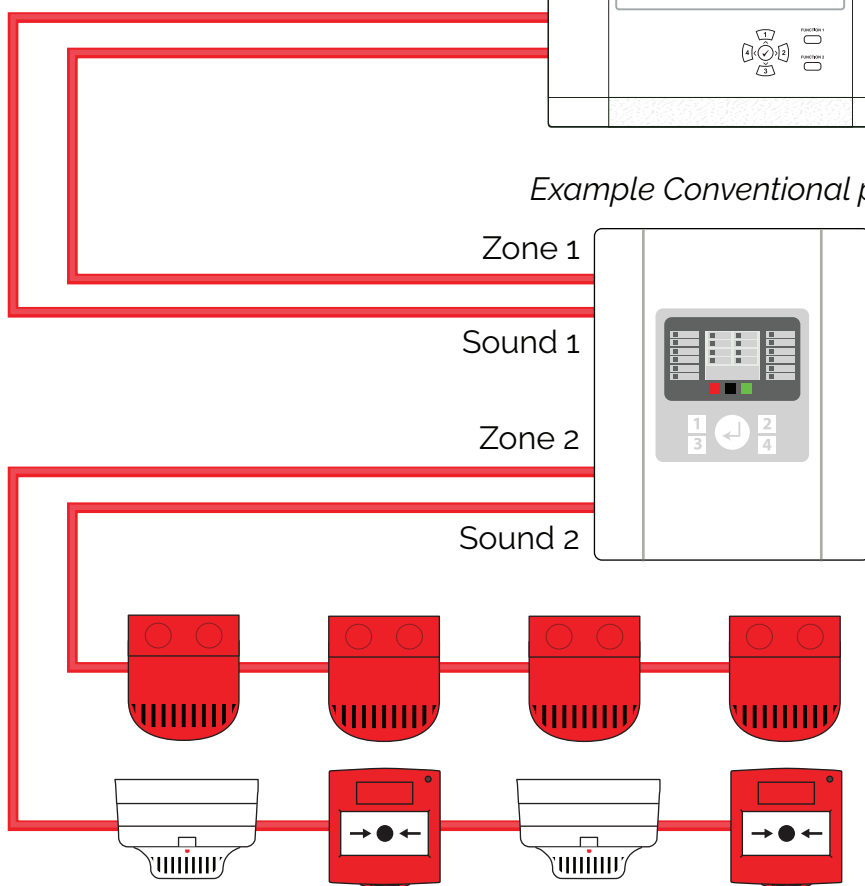

WZM benefits



FAST
INSTALLATION



TRUSTED
TECHNOLOGY



INTUITIVE
INTERFACE



SECURE
WIRELESS



MINIMUM
DISRUPTION



FLEXIBLE
CONFIGURATION



COST
SAVING



EN54-25
CERTIFIED

Wireless devices packed with features*

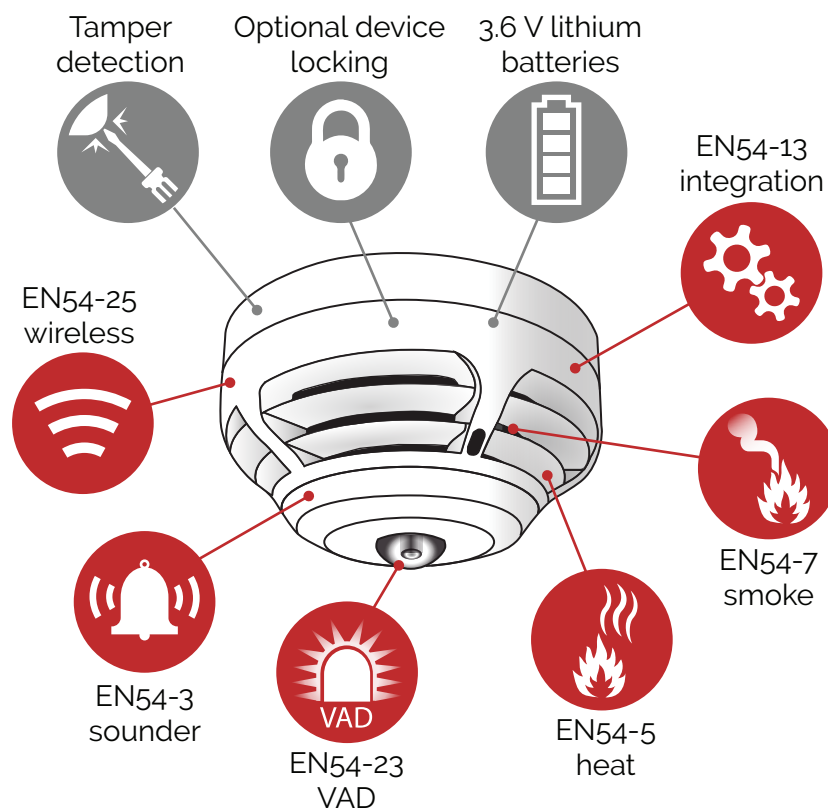

* Example shown SC-23-0220-0001-WZ

WZMs

SC-13-1100-0001-WZ



INTELLIGENT WIRELESS ZONE MONITOR (230 VAC VERSION)

- Wireless device communication
- Quick and easy to install
- 80 character display
- PSU and standby battery included

SC-13-2100-0001-WZ



INTELLIGENT WIRELESS ZONE MONITOR (24 VDC VERSION)

- Wireless device communication
- Quick and easy to install
- 80 character display
- Requires 24 VDC power

Detection

SC-21-0200-0001-WZ



WIRELESS DUAL SMOKE / HEAT DETECTOR

- Flexible detection; smoke and/or heat
- 3x 3.6 V Lithium batteries included

SC-22-0200-0001-WZ



WIRELESS DUAL SMOKE / HEAT DETECTOR AND COMBINED SOUNDER

- Flexible detection; smoke and/or heat
- 32 sounder tones
- 3x 3.6 V Lithium batteries included

SC-23-0210-0001-WZ



WIRELESS DUAL SMOKE / HEAT DETECTOR AND COMBINED SOUNDER BEACON (VAD RED FLASH)

- Flexible detection; smoke and/or heat
- 32 sounder tones
- Part 23 beacon (category C-3-9.5)
- 3x 3.6 V Lithium batteries included

SC-23-0220-0001-WZ



WIRELESS DUAL SMOKE / HEAT DETECTOR AND COMBINED SOUNDER BEACON (VAD WHITE FLASH)

- Flexible detection; smoke and/or heat
- 32 sounder tones
- Part 23 beacon (category C-3-12)
- 3x 3.6 V Lithium batteries included

Sounders

SC-31-0100-0001-WZ



WIRELESS RED SOUNDER

- 32 sounder tones
- 3x 3.6 V Lithium batteries included

SC-31-0200-0001-WZ



WIRELESS WHITE SOUNDER

- 32 sounder tones
- 3x 3.6 V Lithium batteries included

Ceiling beacons

SC-33-0110-0001-WZ



RED SOUNDER AND CEILING BEACON (VAD RED FLASH)

- 32 sounder tones
- Part 23 beacon (category C-3-9.5)
- 3x 3.6 V Lithium batteries included

SC-33-0120-0001-WZ



RED SOUNDER AND CEILING BEACON (VAD WHITE FLASH)

- 32 sounder tones
- Part 23 beacon (category C-3-12)
- 3x 3.6 V Lithium batteries included

SC-33-0210-0001-WZ



WHITE SOUNDER AND CEILING BEACON (VAD RED FLASH)

- 32 sounder tones
- Part 23 beacon (category C-3-9.5)
- 3x 3.6 V Lithium batteries included

SC-33-0220-0001-WZ



WHITE SOUNDER AND CEILING BEACON (VAD WHITE FLASH)

- 32 sounder tones
- Includes part 23 beacon (category C-3-12)
- 3x 3.6 V Lithium batteries included

Wall beacons

SC-32-0110-0001-WZ



RED SOUNDER AND WALL BEACON (VAD RED FLASH)

- 32 sounder tones
- Part 23 beacon (category W-3-5.11)
- 3x 3.6 V Lithium batteries included

SC-32-0120-0001-WZ



RED SOUNDER AND WALL BEACON (VAD WHITE FLASH)

- 32 sounder tones
- Part 23 beacon (category W-2.4-6)
- 3x 3.6 V Lithium batteries included

SC-32-0210-0001-WZ



WHITE SOUNDER AND WALL BEACON (VAD RED FLASH)

- 32 sounder tones
- Part 23 beacon (category W-3-5.11)
- 3x 3.6 V Lithium batteries included

SC-32-0220-0001-WZ



WHITE SOUNDER AND WALL BEACON (VAD WHITE FLASH)

- 32 sounder tones
- Part 23 beacon (category W-2.4-6)
- 3x 3.6 V Lithium batteries included

Call point

SC-51-0100-0001-WZ



WIRELESS FIRE MANUAL CALL POINT

- Protective cover
- 2x breakable tags
- 3x 3.6 V Lithium batteries included

I/O unit

SC-41-0200-0001-WZ



DUAL INPUT DUAL OUTPUT UNIT

- Full wireless communication with WZM
- 2x resistor monitored inputs
- 2x outputs rated 1 A at 30 VDC
- 3x 3.6 V Lithium batteries included

Door controllers

SC-44-0200-0001-WZ



SMARTDOOR (WHITE)

- 100% wireless and controlled by the WZM
- Fully addressable
- 2x C 1.5 V Alkaline batteries included

SC-44-0300-0001-WZ



SMARTDOOR (BLACK)

- 100% wireless and controlled by the WZM
- Fully addressable
- 2x C 1.5 V Alkaline batteries included

Carriage

COURIER-NEXTDAY



STANDARD NEXT DAY DELIVERY

COURIER-BY-12.00



BY 12.00 NEXT DAY DELIVERY

COURIER-BY-10.30



BY 10.30 NEXT DAY DELIVERY

COURIER-SATURDAY-BY-12.00



SATURDAY DELIVERY BY 12.00

COURIER-SATURDAY-BY-10.30



SATURDAY DELIVERY BY 10.30



Technology House
Sea Street
Herne Bay
Kent
CT6 8JZ

emsgroup.co.uk/contact

