



W50 Consultants Specification for a Wireless/Hybrid Addressable Fire Detection System

**Issue July 2022
Rev 6.5**

This document is provided for fire system documentation where wireless or hybrid systems/devices have been identified as the preferred solution. Any text and/or images can be freely used and lifted directly from any part of this document to produce a generic specification for tender purposes.

Part 1:

Introduction and overview of EN54 wireless and hybrid fire detection systems

Introduction

The **EN 54 Fire detection and fire alarm systems** is a mandatory standard that specifies requirements and laboratory test for every component of fire detection and fire alarm system and it allows the free movement of construction products between countries of the European Union market.

It was developed and approved by European Committee for Standardization (**CEN**, French: Comité Européen de Normalisation).

This standard is widely recognized around the world for several countries outside of European Union.

According to the Construction Products Regulation (EU) no 305/2011, it is mandatory that Fire Detection and Fire Alarm equipment is certified under **EN 54** Standard by an authorized Certification Body.

The standard requirements and test methods for fire alarm products has been developed to meet the minimum requirements and testing of fire alarm products that will provide a means of ensuring acceptable safety level, which will be the major benefit to all European countries and which will contribute in the reduction of cost related to fires.

The standard has been published in a number of parts – *refer to the EN54 family parts for details further within this document.*

This document is designed to focus on the **wireless and hybrid** components of fire detection and alarm systems and references other subsets of EN54 for completeness and clarity only.

EN 54 Standard Family Parts

The standard has been published in a number of parts:

- EN 54 part 1 Fire detection and fire alarm systems. Introduction
- EN 54 part 2 Fire detection and fire alarm systems. Control and indicating equipment (Fire alarm control panel)
- EN 54 part 3 Fire detection and fire alarm systems. Fire alarm devices. Sounders
- EN 54 part 4 Fire detection and fire alarm systems. Power supply equipment
- EN 54 part 5 Fire detection and fire alarm systems. Heat detectors. Point detectors
- EN 54 part 7 Fire detection and fire alarm systems. Smoke detector. Point detectors using scattered light, transmitted light or ionization
- EN 54 part 9 Components of automatic fire detection systems. Methods of test of sensitivity to fire
- EN 54 part 10 Fire detection and fire alarm systems. Flame detector. Point detectors
- EN 54 part 11 Fire detection and fire alarm systems. Manual call point
- EN 54 part 12 Fire detection and fire alarm systems. Smoke detectors. Line detectors using an optical light beam
- EN 54 part 13 Fire detection and fire alarm systems. Compatibility assessment of system components
- EN 54 part 14 Fire detection and fire alarm systems. Planning, design, installation, commissioning, use and maintenance.
- EN 54 part 15 Fire detection and fire alarm systems. Point detectors using a combination of detected fire phenomena.
- EN 54 part 16 Fire detection and fire alarm systems. Components for fire alarm voice alarm systems. Voice alarm control and indicating equipment
- EN 54 part 17 Fire detection and fire alarm systems. Short circuit isolators
 - **Note in certain configurations this standard is applicable to wireless components within a fire alarm system.**
- EN 54 part 18 Fire detection and fire alarm systems. Input/output devices
 - **Note in certain configurations this standard is applicable to wireless components within a fire alarm system.**
- EN 54 part 20 Fire detection and fire alarm systems. Aspirating smoke detector

- EN 54 part 21 Fire detection and fire alarm systems. Alarm transmission and fault warning routing equipment
- EN 54 part 22 Fire detection and fire alarm systems. Line type heat detectors
- EN 54 part 23 Fire detection and fire alarm systems. Fire alarm devices. Visual alarms
- EN 54 part 24 Fire detection and fire alarm systems. Voice alarms - Loudspeakers
- **EN 54 part 25 Fire detection and fire alarm systems. Components using wireless links and system requirements**
- EN 54 part 26 Fire detection and fire alarm systems. Point fire detectors using Carbon Monoxide sensors
- EN 54 part 27 Fire detection and fire alarm systems. Duct smoke detectors

Wireless Standards

Independent of any EN54 requirements wireless components utilised within a fire alarm systems must comply with mandatory “wireless regulations”.

Note that these regulations may differ between countries – specifically with reference to the frequency deployed and power band.

Before installing wireless equipment in a country one needs to ensure that the equipment being deployed satisfies that countries regulatory requirements.

This document lists the requirements of wireless requirements as required by the European Union applicable to FD&A equipment compliant to EN54-25.

Minimum wireless standards

ETSI 300:220	Electromagnetic compatibility and Wireless spectrum matters (ERM); Short Range Devices (SRD); Wireless equipment to be used in the 25 MHz to 1,000 MHz frequency range with power levels ranging up to 500 mW; Part 1: Technical characteristics and test methods
ETSI 301:489	EMC standards applicable to Article 3 1.b of the Radio Equipment Directive 2014/53/EU
BSEN 60950-1	General safety requirements intended to reduce risks of fire, electric shock or injury for the operator and layman who may come into contact with the equipment and, where specifically stated, for a service person.

ETSI

ETSI standards could be described in general as being '*definitions and specifications for products and processes requiring repeated use*'. They are certainly a set of rules for ensuring quality.

ETSI does not certify equipment, nor does it keep records of equipment that is compliant to its standards. Some organizations use ETSI standards as the basis for certification schemes. This can be done for commercial reasons or, in some countries outside the European Union, for compliance with National regulations.

Interoperability

The main aim of standardization is to enable interoperability in a multi-vendor, multi-network, multi-service environment. Businesses cannot afford to allow products and services for which there is great demand not to interoperate and thus not to come into being.

ETSI is therefore committed to ensuring that interoperability cannot be obstructed by poor or insufficient standardization.

ETSI produces globally-applicable standards for ICT (Information and Communications Technologies), including fixed, mobile, wireless, converged, broadcast and internet technologies.

Acronyms:

There are many acronyms used within the fire alarm industry. Some acronyms appear to be used generically by manufacturers, approval bodies, installers and end users whilst other may be manufacturer specific.

The following acronyms will be used throughout this document.

EN	European Norm
FD&A(s)	Fire Detection and Alarm (System)
CIE	Control and indicating equipment also known as FAP
FAP	Fire Alarm Panel
Detection Devices	Typically heat and smoke detectors
MCP	Manual call point
I/O	Input / Output
Ident	Unique device identification
VAD	Visual Alarm Device
BAFE	British Approvals for Fire Equipment
LED	Light emitting diode

Focus of this document with respect to EN54 Standards.

This document describes *wireless* fire detection and alarm devices / components and refers to various component and or system standards applicable when *wireless* components are utilised wholly or in part to configure fire detection and alarm system that will comply with EN standards.

This document is designed to focus on the *wireless* component of a fire detection and alarm system and references other subsets of EN54 for completeness and clarity only.

EN54 pt 25 - (*Fire detection and fire alarm systems - Components using wireless links and system requirements*) is therefore the main focus of this document.

This document also refers to *wireless communication* standards applicable to wireless communication equipment / components and therefore a prerequisite to all compliant wireless equipment / components independent of EN54.

This document also references national codes of practice and or standards in pertinent sections to illustrate and or highlight operational requirements and or performance requirements of fire alarm systems. i.e. BS5839 pt1

A complete list of referenced standards may be found further within this document.

Any pertinent subset of requirements / standards of EN54 that are applicable / maybe required to create a compliant EN system that are generic within all types of fire detection and alarm systems be they, wired, conventional, or analogue addressable systems etc. i.e. Power Supplies (EN54-4) or EN54-5 smoke detectors etc. whilst referred to within this document may not be detailed within this document.

When specifying a CIE, from the perspective of this document it is assumed that the minimum requirements of EN54 pt2 and EN54 pt 4 are applicable to the CIE being specified / installed.

Note that there are specific events that are required to be annunciated / reported / displayed within a fire alarm system compliant to EN54-25.

- These events may be annunciated directly by/at the CIE or alternately at the wireless interface if the FD&AS includes interfaces within its configuration.
- Dependent on the configuration therefore a CIE may require **additional** requirements / software over and above the standard CIE EN 54 pt2.
- This document highlights the additional requirements and configurations.

Generic Fire Detection Configurations

All fire detection and alarm systems generically comprise of a CIE, a number of detection devices, input and output units and audio-visual devices. Further some FD&A system configurations include networking equipment to interlink a number of CIE and may also integrate with PC based graphics software and other building control systems.

Fire Detection systems are generically categorised as:

Wired FD&A systems

- These systems use various types of cables / wires to interconnect all the components of the system. Note wired systems are further generically categorised as conventional or addressable.

Conventional FD&A systems

- A conventional fire alarm system is generally accepted as being the *simplest* of fire alarm system.
- In a Conventional Fire Alarm System, a number of call points and detectors are wired to the Fire Alarm Control Panel on a zonal basis. It is not possible to know which device has operated within the system unless a single device is wired into each zone.
- Typically, the sensing elements within a conventional system are fixed point alarm devices. Typically, the device is normal or in alarm and it is the device itself that initiates the event.

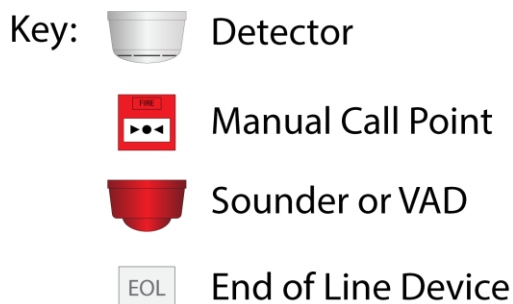
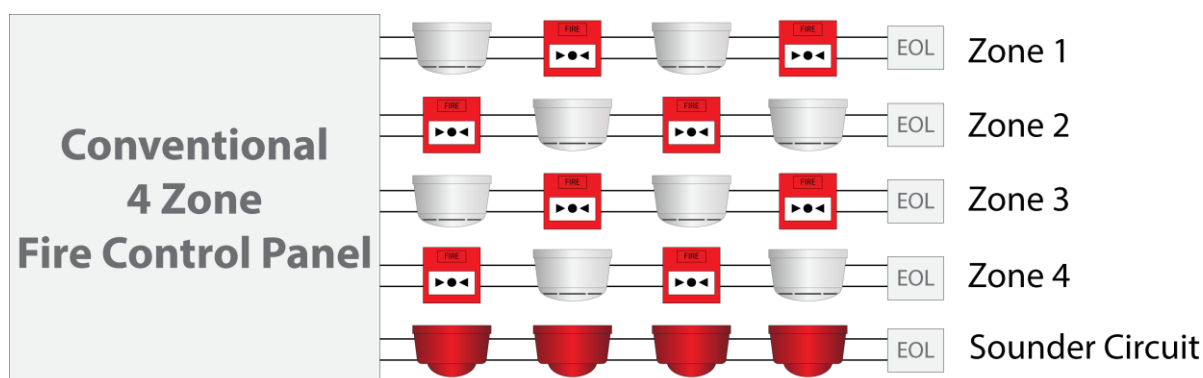

Addressable FD&A systems

- An addressable system as opposed to a conventional system is able to identify the source of an event on an individual device by device basis.
- Devices with regard to sensing technology in addressable systems are generically similar to conventional systems.
- Generically addressable systems provide for more functionality than conventional systems and provide greater scalability.

Analogue Addressable systems

- Analogue Addressable Fire Alarm Systems are often referred to as Intelligent Fire Alarm Systems. Analogue Devices in addition to being addressable are able to provide signals representing the value of detected phenomena. Generically there are two types of Analogue Addressable Systems
- In type one the analogue sensors provide the CIE real time signals / data of the environment and the CIE interprets whether there is a fire, fault, pre-alarm or other event.
- In type two the analogue sensors effectively incorporate their own microprocessor which evaluates the environment around it, and communicates to the CIE as to a fire, fault, pre-alarm or other event.

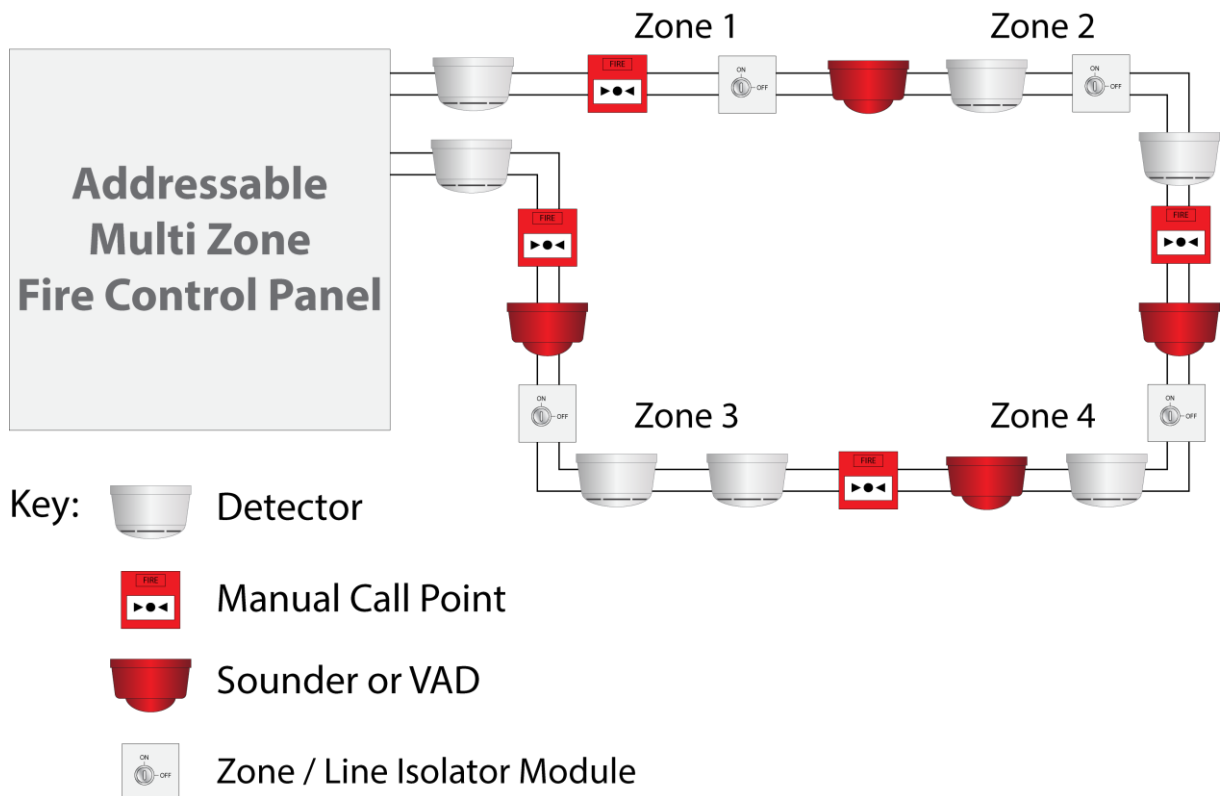

Wireless Fire Alarm System

- Wireless fire alarm systems are an effective alternative to traditional wired fire alarm systems for all applications. They utilize secure, wireless communications to interconnect the sensors and devices with the CIE. It is a simple concept, which provides many unique benefits.
- Wireless fire detection technology can be utilized in an entire fire alarm system or be part of a hard-wired system.

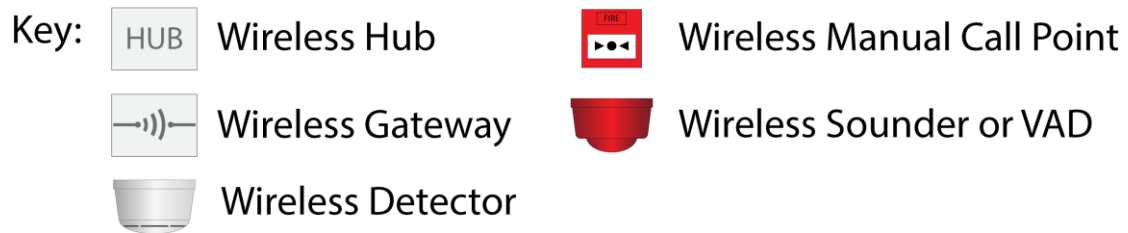
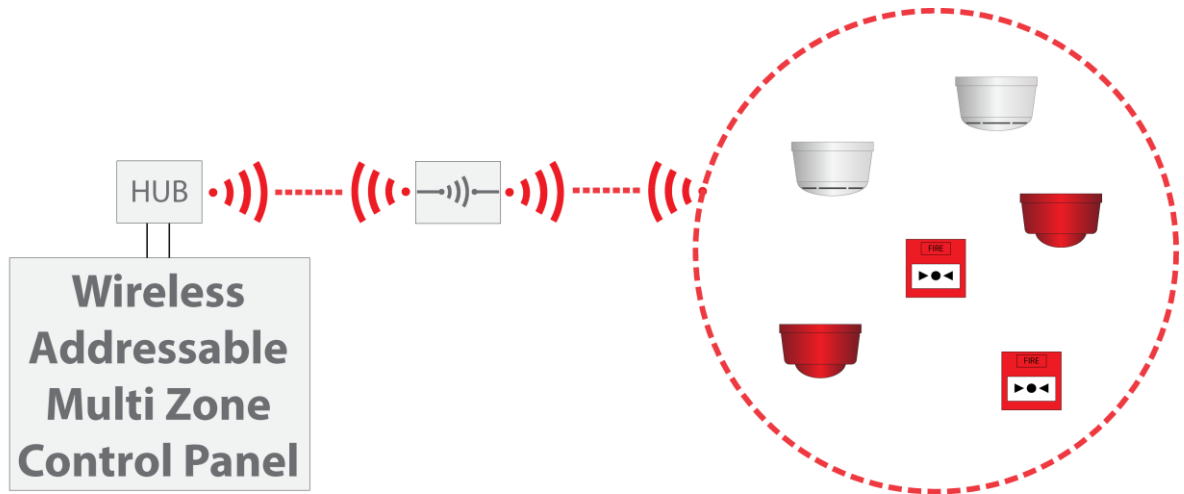

Wireless Fire Detection Configurations

It is important when specifying a wireless fire detection system to state exactly what type of wireless system is required or combination of wireless technologies.

Generically wireless systems can be categorized as:

- Partial Wire free (Hybrid) (addressable)
- Complete Wire free FD&A systems (addressable)

Partial Wire Free Fire Alarm System

Partial wire free systems utilise an interface module to supervise the wireless devices and communicate events to / from the CIE. They are also commonly referred to as Hybrid systems – a mix of two technologies – wire and wire free.

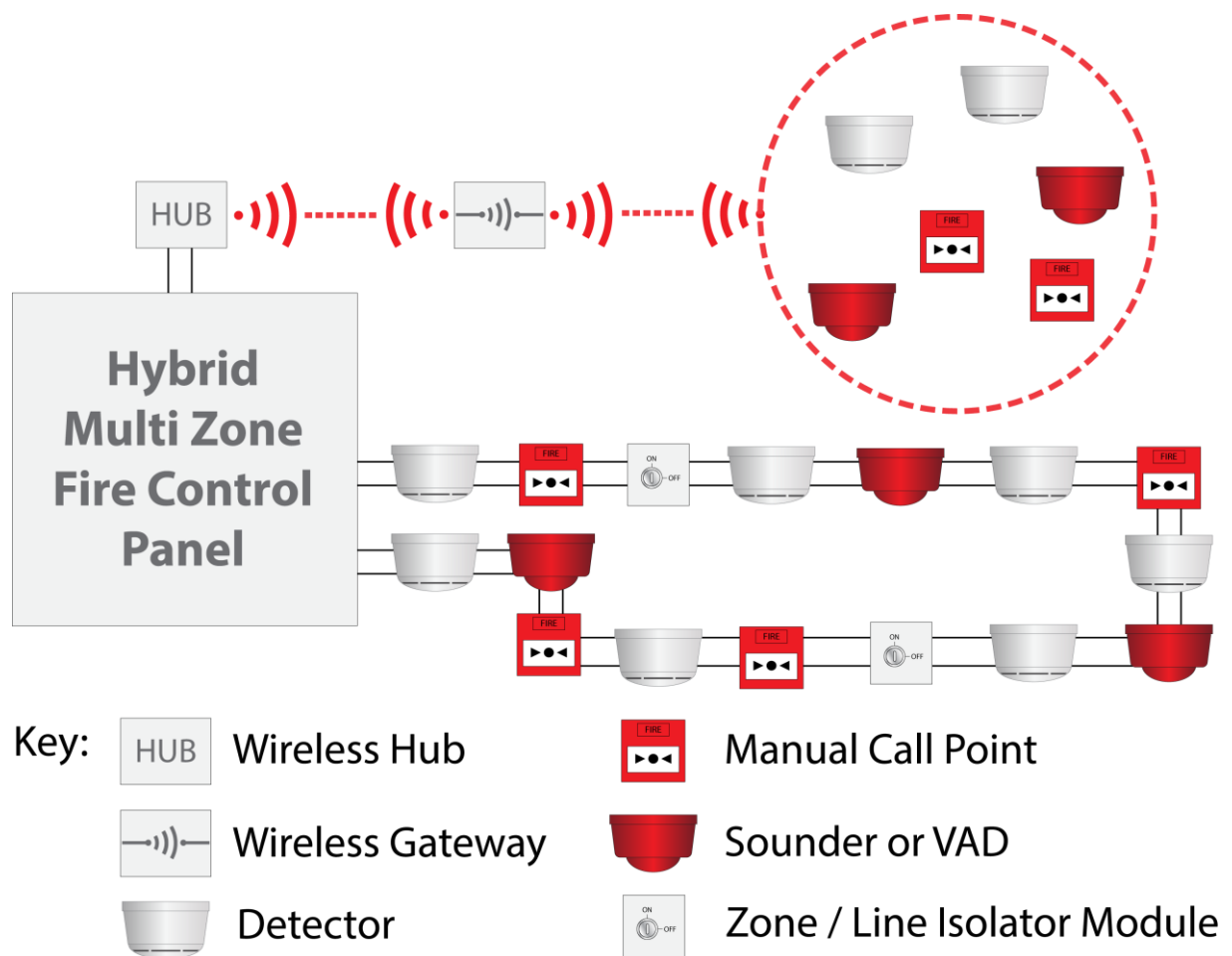

Wireless Interface Modules

The wireless interface module for hybrid systems comprises of two variants:

High level protocol interface (Intelligent interface module) in that the module is fully compatible with the CIE loop protocol and is "seen" as a loop device which has the ability to supervise wireless devices.

Low level interface in that whilst the interface itself is highly intelligent and complies with EN54-25 requirements it only reports common Fire and Fault events to the CIE via a input / output module on the CIE loop.

Intelligent Interface Module

- Incorporate the CIE loop protocol – i.e., the unit is able to communicate directly with the CIE.
- Can be either loop or remote powered.
- Can incorporate loop isolators within the unit
- Aerials can be internal to the unit or external mounted
- These interfaces should provide the following:

All wireless optical and heat detector variants, call-points and electronic alarm indication units shall communicate directly to a localised intelligent interface module for onward communication to the CIE.

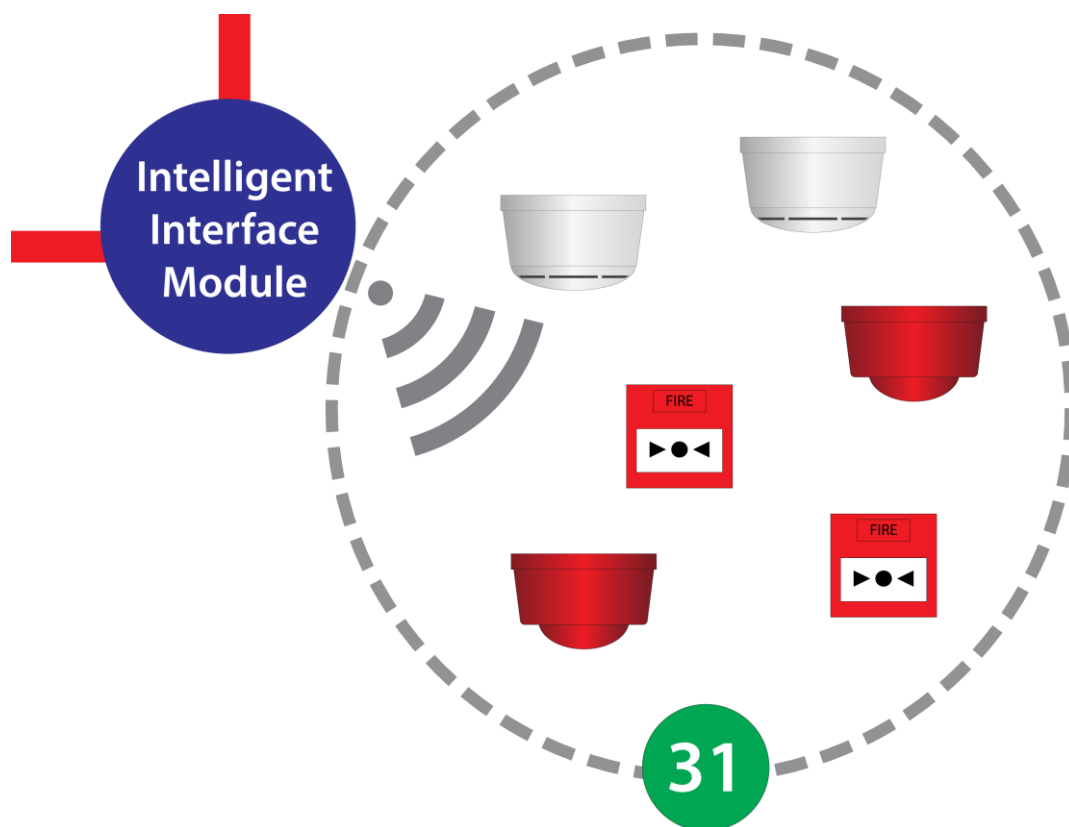

The intelligent interface module shall have LED indication of power status and fault indication.

The intelligent interface module shall have the ability to use UHF 868 MHz frequency transmitter/receivers.

The intelligent interface module shall use diversity aerial configuration for increased signal reliability.

The intelligent interface module shall be capable of self-testing and analysing its power sources on a constant basis, reporting any internal battery fault within 100 seconds.

The intelligent interface module shall have the capability to monitor up to 31 directly logged on devices selectable from detectors, callpoints, sounders and interface accessories.

The intelligent interface module shall have as standard TTL serial input/output facility. It shall be capable of diagnostics by the use of a laptop or portable computer.

There should also be 72 hours battery back-up either with onboard or remote battery pack.

Low Level Interface Module

The term Low level interface applies to the connection method between the CIE and the wireless interface only. The wireless module retains all functionality and compliance required of such a unit re the wireless requirements.

These units do NOT incorporate CIE loop protocol but report fire and fault conditions to the CIE via a simple programmable input / output unit. The CIE i/o device will be programmed such that it will accept a fire or fault condition, indicate to the RLM to operate audio visual devices and be able to "reset" the wireless interface module.

As more than 90 % of all addressable CIE include a programmable I/O unit within their product range this is an ideal way to incorporate wireless product into a system without the costs associated with full protocol implementation.

Generally speaking, this wire free solution is for installations that require a few wireless devices to be deployed within the site and the CIE being deployed does not include a high-level wireless module.

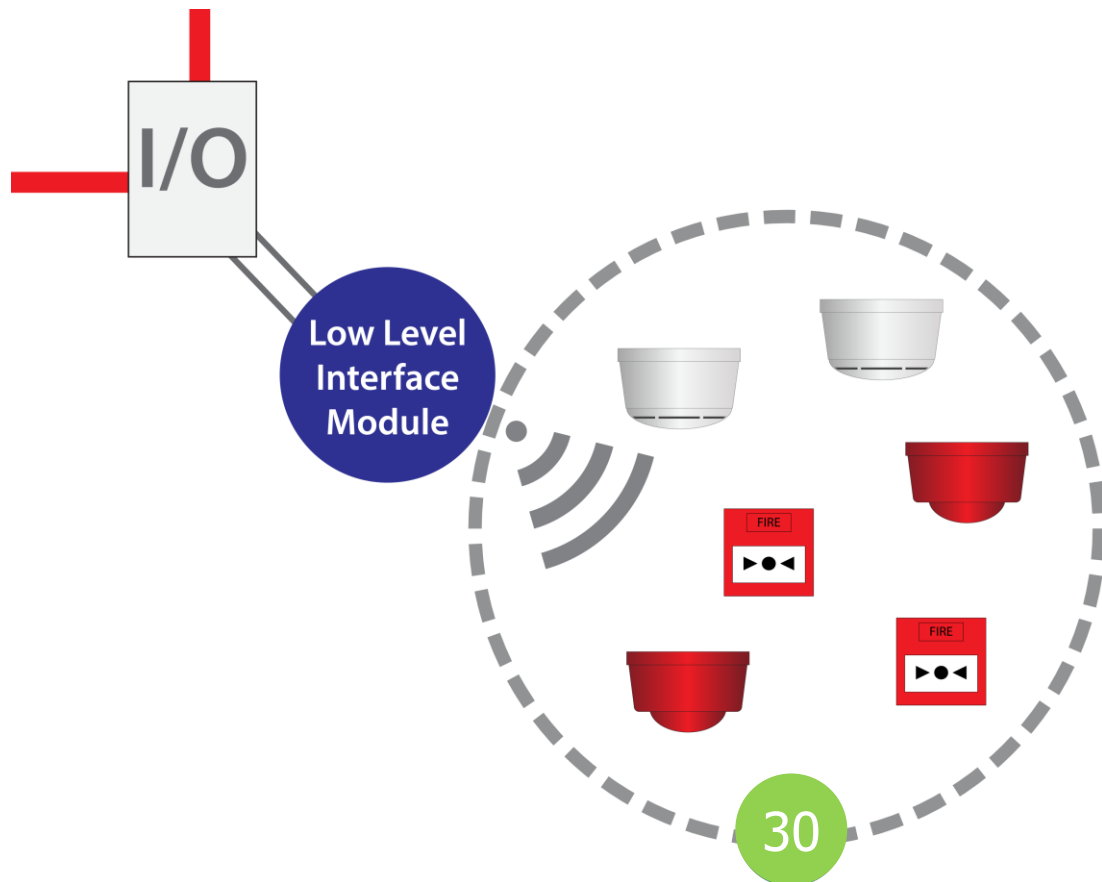

Complete Wireless FD&A Systems (Addressable)

Table of Contents

General Requirements

Standards and Specifications

Specification for Wireless Analogue Addressable Wireless Fire Detection and Alarm System

System Components

Control & Indicating Equipment – CIE

System Configuration

Mechanical Design

Supervision and Fault Reporting

Cables for Connection of Wireless Hub to CIE

Networking

Wireless Hub

Wireless Gateway

Optical Analogue Addressable Smoke Detectors

Analogue Addressable Heat Detector

Analogue Addressable Multi-Sensor Detector

Call point

Addressable Wireless Input/Output Transmitter

Electronic Sounder/Visual Indicator

Combined Detector Sounder/Visual Indicator

Visual Indicator

Door Controller

Wireless Fire Alarm System Design

Training

Maintenance

General Requirements

The Fire Alarm contractor shall be responsible for the design, supply, installation, commissioning and maintenance of wireless addressable fire detection and alarm systems.

The Fire Alarm contractor shall be capable of providing a remote alarm monitoring service with a direct communications link to the Fire Service.

The Fire Alarm contractor shall have an adequate number of competent staff trained and experienced in the design, installation, commissioning and maintenance of wireless addressable fire detection and alarm systems.

The Fire Alarm contractor shall have a minimum of 10 years experience in designing, installing, commissioning and maintaining fire detection and alarm systems, at least 5 years of which must be with wireless addressable systems.

The Fire Alarm contractor must be BAFE certificated.

The main equipment proposed for use in the wireless addressable fire detection and alarm system shall be approved by at least one of the following UK or international organisations:

- UKAS 3rd Party Test House
- Loss Prevention Council (LPC)
- British Standards Institution (BSI)
- Underwriters Laboratories (UL)

The Fire Alarm contractor shall have available a complete set of technical manuals for all equipment installed. This must cover technical specification, system design recommendations and guidelines for installation, commissioning, operating and maintaining the proposed equipment.

The Fire Alarm contractor, given reasonable notice, shall permit the buyer, or its nominated agent, to conduct a quality audit at the premises where the proposed equipment is manufactured.

All variations from this specification that the contractor proposes to make shall be clearly indicated in writing, making reference to the relevant paragraph(s) of this specification.

Standards and Specifications

Where applicable, the fire detection and alarm system, and installation, shall comply fully with the following British Standards and/or other nominated rules and regulations:

EN 54 Standard Family Parts

The standard has been published in a number of parts:

- EN 54 part 1 Fire detection and fire alarm systems. Introduction
- EN 54 part 2 Fire detection and fire alarm systems. Control and indicating equipment (Fire alarm control panel)
- EN 54 part 3 Fire detection and fire alarm systems. Fire alarm devices. Sounders
- EN 54 part 4 Fire detection and fire alarm systems. Power supply equipment
- EN 54 part 5 Fire detection and fire alarm systems. Heat detectors. Point detectors
- EN 54 part 6a Fire detection and fire alarm systems heat detectors; Rate-of-Rise point detectors without a static element {WITHDRAWN}
- EN 54 part 7 Fire detection and fire alarm systems. Smoke detector. Point detectors using scattered light, transmitted light or ionization
- EN 54 part 8 Components of automatic fire detection systems. Specification for high temperature heat detectors {WITHDRAWN}
- EN 54 part 9 Components of automatic fire detection systems. Methods of test of sensitivity to fire
- EN 54 part 10 Fire detection and fire alarm systems. Flame detector. Point detectors
- EN 54 part 11 Fire detection and fire alarm systems. Manual call point
- EN 54 part 12 Fire detection and fire alarm systems. Smoke detectors. Line detectors using an optical light beam
- EN 54 part 13 Fire detection and fire alarm systems. Compatibility assessment of system components
- EN 54 part 14 Fire detection and fire alarm systems. Planning, design, installation, commissioning, use and maintenance.
- EN 54 part 15 Fire detection and fire alarm systems. Point detectors using a combination of detected fire phenomena.
- EN 54 part 16 Fire detection and fire alarm systems. Components for fire alarm voice alarm systems. Voice alarm control and indicating equipment
- EN 54 part 17 Fire detection and fire alarm systems. Short circuit isolators

- EN 54 part 18 Fire detection and fire alarm systems. Input/output devices
- EN 54 part 20 Fire detection and fire alarm systems. Aspirating smoke detector
- EN 54 part 21 Fire detection and fire alarm systems. Alarm transmission and fault warning routing equipment
- EN 54 part 22 Fire detection and fire alarm systems. Line type heat detectors
- EN 54 part 23 Fire detection and fire alarm systems. Fire alarm devices. Visual alarms
- EN 54 part 24 Fire detection and fire alarm systems. Voice alarms - Loudspeakers
- EN 54 part 25 Fire detection and fire alarm systems. Components using wireless links and system requirements
- EN 54 part 26 Fire detection and fire alarm systems. Point fire detectors using Carbon Monoxide sensors
- EN 54 part 27 Fire detection and fire alarm systems. Duct smoke detectors

EN 54 standards have been developed by European Committee for Standardization with the approval of their members.

- Austria, ASI OENORM EN 54-
- Belgium, NBN EN 54-
- Bulgaria, BDS EN 54-
- Croatia, HZN HRN EN 54-
- Cyprus, CYS EN 54-
- Czech Republic, UNMZ CSN EN 54-
- Denmark, DS DS/EN 54-
- Estonia, EVS EVS-EN 54-
- Finland, SFS SFS-EN 54-
- Former Yugoslav Republic of Macedonia, ISRM MKC EN 54-
- France, AFNOR NF EN 54-
- Germany, DIN EN 54-
- Hungary, MSZT MSZ EN 54-
- Iceland, IST ÍST EN 54-
- Ireland, NSAI I.S. EN 54-
- Italy, UNI EN 54-
- Latvia, LVS EN 54-
- Lithuania, LST EN 54-
- Luxembourg, ILNAS EN 54-
- Malta, MCCA SM EN 54-1
- Netherlands, NEN NEN-EN 54-
- Norway, SN NS-EN 54-
- Poland, PKN PN-EN 54-
- Portugal, IPQ EN 54-

- Romania, ASRO SR EN 54-
- Slovakia, SUTN STN EN 54-
- Slovenia, SIST EN 54-
- Spain, AENOR UNE-EN 54-
- Sweden, SIS SS-EN 54-
- Switzerland, SNV SN EN 54-
- Turkey, TSE TS EN 54-
- United Kingdom, BSI BS EN 54-
- Albania, DPS S SH EN 54-
- Bosnia and Herzegovina, BAS EN 54-
- Montenegro, ISME MEST EN 54-
- Serbia, ISS SRPS EN 54-

In the United Kingdom it superseded BS 5445: Part 1:1977. BS EN 54-1:1996 was published in December 1996.

BS 5839: Fire detection and fire alarm systems for buildings:

BS 5839-1: Code of practice for system design, installation commissioning and maintenance.

BS 5839-3: Specification for automatic release mechanisms for certain fire protection equipment.

BS 5839-6: Code of practice for the design and installation of fire detection and alarm systems in dwellings.

BS 5446-1: Specification for smoke alarms

BS7273: Code of practice for the operation of fire measures.

BS7273-4: Actuation of release mechanisms for doors.

BS7671: Requirements for electrical installations. IEE Wiring Regulations Seventeenth Edition.

HTM 05-03 Fire safety in healthcare premises. Alarm and detection systems.

BS EN 54: Fire detection and fire alarm systems.

BS EN 54-2: Control and indicating equipment

BS EN 54-3: Fire alarm devices - Sounders

BS EN 54-4: Power supply equipment

BS EN 54-5: Heat detectors - Point detectors

BS EN 54-11: Manual call points

BS EN 54-7: Smoke detectors - Point detectors.

BS EN 54-12: Smoke detectors - Optical beam detectors

BS EN 54-25: Wireless EU Standards

BS EN 60702-1: Cables

BS EN 60702-2: Terminations

Part 2:

Specification

Specification for Wireless Analogue Addressable Wireless Fire Detection and Alarm System

The area(s) shall be protected using wireless detectors, call points and alarm indication devices capable of transmitting their status back via wireless gateway(s), which transmits to a central Wireless Hub for interpretation of the data and action as appropriate. The site should have a full wireless survey ensuring the relevant signal headroom is adhered to as stated in EN54:25. The wireless fire detection and alarm system shall be selected and installed in accordance with the following:

System Components

The fire alarm system shall be analogue addressable and devices are to be installed throughout the areas nominated as part of the system design and in conjunction with the site survey report.

The system shall consist of analogue addressable fire detection, wireless smoke and heat detector, call-points, sounders, and visual alarm indicators which communicate via wireless gateway(s) to a wireless Hub.

All wireless linked devices shall be powered by an internal battery pack consisting of easy to source and replace alkaline battery cells. The battery pack shall give the device an operating life of at least three years in normal use before it needs to be replaced. The battery cells shall be divided into two sets to provide backup in case of the failure of one set. Each set shall be monitored and reported as a battery fault at the control panel in case of failure. When battery power capacity is low, a low battery condition shall be indicated at the control panel allowing at least 30 days for the battery pack to be replaced.

Battery fault and battery low conditions shall be reported as such at the control panel. A general device fault condition is not sufficient.

The system shall be designed in accordance with the requirements of BS5839-1: 2002 +A2:2008 and all relevant parts of EN54 for which third party certification should be provided.

Control & Indicating Equipment – CIE

The control and indicating equipment shall form the central processing unit of the system, receiving and analysing signals from fire sensors, providing audible and visual information to the user, initiating automatic alarm response sequences and providing the means by which the user interacts with the system.

The control and indicating equipment shall be modular in construction to allow for future extension of the system.

The control and indicating equipment shall be easily configurable so as to meet the exact detection zone and output mapping requirements of the building.

The control and indicating equipment shall be microprocessor based and operate under a multitasking software program. Operating programs and configuration data must be contained in easily up-datable, non-volatile memory (EEPROM). The use of 'burnt' EPROMs will not be permitted.

The control and indicating equipment shall incorporate a real-time clock to enable events to be referenced against time and date. This clock shall be accurate to within 1 minute per year under normal operating conditions. The clock must have the facility to compensate for time changes due to summer and winter daylight saving.

It shall be possible for an engineer to perform configuration updates on site by plugging a portable personal computer into the control and indicating equipment. Configuration data shall be retained on the personal computer's hard drive and be capable of being backed up onto a central storage system.

The CIE continuously monitors the status of all fire detection and initiating devices and on determining a fire alarm condition shall indicate the source of the fire on the panel LCD and any programmed indicators and automatically initiate pre-programmed alarm, evacuation and control actions.

When showing alarms on its LCD display the control panel shall initially show the first and last zone of alarm, the alarm type, the number of alarms and the time and date. Fire alarms take priority but the user shall be able to select display of other alarm types, including non-fire events and disablements as faults.

Each control panel shall have an internal audible alarm signal with different programmable patterns to distinguish between fire alarm, fault and non-fire conditions. The fire audible signal shall take priority.

Each panel shall have capacity to store a historic log of at least 500 system alarms and events together with the time and date they occurred.

The company responsible for the installation shall operate an approved document control system for the retention of configuration data.

The control and indicating equipment shall meet the requirements of BS EN 54 part 2 and BS EN 54 part 4. The fire panel shall be capable of being installed to BS 5839 part 1.

The control panel shall have the capability to run up to 504 addressable devices.

Programming of the address code shall either be via the control and indicating equipment or via a dedicated programming tool.

The control and indicating equipment shall incorporate a key switch to prevent unauthorised use of the manual controls.

System Configuration

Addressable input and output devices shall be connected to Gateways capable of accepting up to 31 wireless devices.

The control and indicating equipment shall have a minimum capacity for operating 126 wireless devices. This shall be extendible up to a maximum capacity of 8 addressable loops.

It shall be possible to allocate all 126 addressable devices to a single zone.

In order to facilitate re-configuration and system extension, the allocation of addresses to devices shall be independent of their physical arrangement on the system.

The control and indicating equipment shall have provision to drive and monitor repeater panels, providing a repeat of the indications on the control and indicating equipment display and also incorporating the full set of system manual user controls.

The control and indicating equipment shall have provision to house the AC Main power supply and batteries required to power systems. Zonal indication shall be provided by the use of LEDs.

The control and indicating equipment shall have provision for the connection of external power supplies, either local to the control and indicating equipment or distributed throughout the system.

The control and indicating equipment shall have provision for the connection of a printer, either locally or via a parallel port.

The control and indicating equipment shall be capable of interfacing directly to an electronic wireless paging system.

The control and indicating equipment shall be capable of being interfaced with other similar control and indicating equipment without locking up or being affected by feedback signals.

It shall be possible to connect a PC to the control and indicating equipment to display the information that would otherwise appear on the printer.

The control and indicating equipment shall have the facility to enable an on-board communications module to be added to allow wireless or wired local area networking to other controllers.

The control and indicating equipment shall be capable of interfacing with third party equipment via a serial interface.

Mechanical Design

The housings shall be of metal construction and capable of being surface or semi-recessed mounted and shall come complete with cable entries, fixings, knock-outs and covers.

The display component of the control and indicating equipment shall be mounted on a hinged front cover that must not open at an angle greater than 90 degrees to prevent cover damage.

It shall not be possible to open the control and indicating equipment without the use of a special tool.

Supervision and Fault Reporting

The control and indicating equipment shall monitor all critical system components and interconnections (internal and external). In the event of a failure occurring which prevents correct operation of the alarm functions, a fault indicator will light and a message shall be given on the alphanumeric display within 100 seconds of occurrence.

The following faults shall be reported:

- Un-configured Device
- Addressable Device Failure
- Device Not Responding
- Incorrectly Configured Device
- Detector Condition Monitoring Warning
- Repeater/Repeater LCD, Remote Printer Failure
- PSU Fault
- Charger Fault
- Battery Fault(s) including device 30-day warning
- Battery Critical
- Mains Failure
- Auxiliary PSU Failure
- Relay Output Inoperative
- Signalling Fault
- Device Tamper

To help rapid fault finding and repair, the control and indicating equipment shall provide text messages to indicate the precise location of where a fault has occurred in the system.

The control and indicating equipment shall be capable of monitoring and indicating the status of auxiliary units, such as a remote signalling transmitter.

The control and indicating equipment shall have the facility to delay the generation of an event to confirm operation of the monitored device.

The control and indicating equipment, standard power supply unit and standard repeater unit shall comply with at least the EMC requirements described in BS EN 54 part 2 and BS EN 54 part 4.

Cables for connection of external wireless Hub to CIE

Cable used shall comprise one of the following:

Cables that conform to BS 7629

Cables that conform to BS 7846

Cables rated at 300/500V (or greater) that provide the same degree of safety to that afforded by compliance with BS 7629

Standard fire resisting cables should meet the PH 30 classification when tested in accordance with EN 50200 and maintain circuit integrity if exposed to the following test:

A sample of the cable is simultaneously exposed to flame at a temperature of 830 degrees Celsius and mechanical shock for 15 minutes, followed by simultaneous exposure to water spray and mechanical shock for a further 15 minutes.

Enhanced fire resisting cables should meet with the PH 120 classification when tested in accordance with EN 50200 and maintain circuit integrity if exposed to the following test:

A sample of the cable is simultaneously exposed to flame at a temperature of 930 degrees Celsius and mechanical shock for 60 minutes, followed by simultaneous exposure to water spray and mechanical shock for a further 60 minutes.

Internal wireless Hubs

These are plugged directly into the CIE main PCB and require no additional cable.

External diversity aerials are installed directly to the CIE for wireless propagation

Networking

The system must be capable of supporting up to 16 sub panels wirelessly and provide a seamless and full alarm management and panel control capability.

The network shall be a true peer-to-peer system where all main control panels in the network are of the same type with identical software and hardware capabilities.

Every panel can access all the features that the whole network has to offer. A network with a central master panel which controls the network or where only certain panels can display network events or access network functions is not acceptable.

The propagation and display of a fire event across the entire network of control panels shall meet the requirements of BS5839. The propagation and display of a fault event across the entire network of control panels shall take no longer than 100 seconds.

The network must be capable of supporting a maximum distance of 4000m between CIE(s)

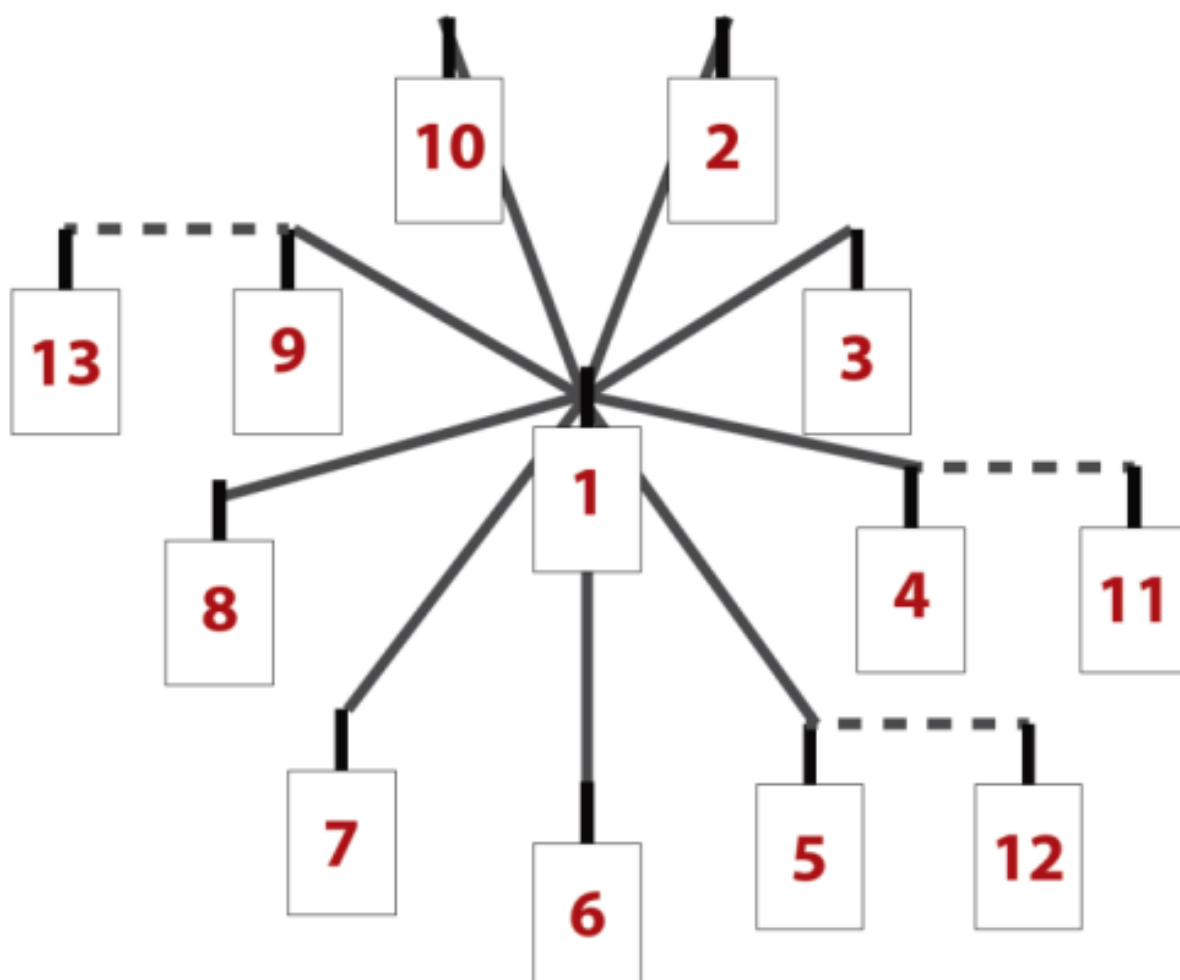

Wireless Hub

The Wireless Fire Alarm System shall be analogue addressable. It shall consist of an external wireless Hub coupled to the Control Panel (C.I.E). via the Loop or an internal wireless hub/PCB which is plugged directly into the CIE main control board.

The external wireless Hubs shall have an individual LCD display along with menu controls to allow manual system programming and interrogation of the system if required.

The wireless Hubs shall have LED indication of power status and fault indication.

The wireless Hub shall be capable of self-testing and reporting any internal fault within 100 seconds.

The wireless Hub shall have the ability to use UHF 868 MHz frequency transmitter/receivers. The unit must be capable of handling multiple gateways each supporting directly logged on wireless devices selectable from detectors, callpoints, sounders and interface accessories.

The wireless Hub shall use diversity aerial configuration for increased signal reliability.

The wireless Hub shall have built in dual transceivers to allow redundancy and increased system reliability.

The external wireless Hub shall have as standard a TTL serial input/output facility. It shall be capable of programming and diagnostics by the use of a laptop or portable computer.

The wireless Hub shall be capable of transmitting information to the C.I.E. as appropriate:

- Pre-alarm
- Alarm
- Fault conditions
- Signal strength readings

The Wireless Hub will be powered from the C.I.E.

Wireless Gateway

Wireless optical and heat detector variants, call-points and electronic alarm indication units shall communicate directly to a localised Gateway for onward communication to the Wireless Hub.

The Gateway shall have LED indication of power status and fault indication.

The Gateway shall have the ability to use UHF 868 MHz frequency transmitter/receivers.

The Gateway shall use diversity aerial configuration for increased signal reliability.

The Gateway shall be capable of self-testing and analysing its power sources on a constant basis, reporting any internal battery fault within 100 seconds.

The Gateway shall have the capability to monitor up to 31 directly logged on devices selectable from detectors, callpoints, sounders and interface accessories.

The Gateway shall have as standard TTL serial input/output facility. It shall be capable of diagnostics by the use of a laptop or portable computer.

The Gateway shall communicate via wireless either directly to the wireless Hub or via additional Gateways.

Gateways shall be connected via an integral PSU to the 230-volt supply or 24-volt supply. There should also be 72 hours battery back-up either with onboard or remote battery pack.

Optical Analogue Addressable Smoke Detectors

All detector assemblies used shall be of a three-part construction:

1. Smoke detector head
2. Wireless address module and battery board
3. Ceiling mount

The detector shall be self-testing and be analogue addressable.

The wireless address module shall have the ability to use UHF 868 MHz frequency transmitter/receivers.

The wireless address module shall house a battery compartment, providing primary and secondary supply support and a microprocessor control unit. The battery pack should be capable of powering the device for five years under normal conditions.

The wireless address module shall contain a factory programmed unique ident code.

The unit shall be fitted with an integral tamper switch, which makes contact with the ceiling mount and also be capable of monitoring detector head removal.

The unit shall be capable of indicating low battery warning with a minimum of thirty days' notice of impending failure.

The unit will transmit its battery condition indicating when the batteries require replacement.

The device shall have non-volatile memory.

The device shall be capable of being logged on to a Gateway and addressed via the Wireless Hub.

The device shall be third party certified and tested to EN54 parts 7 and 25.

Analogue Addressable Heat Detector

All detector assemblies used shall be of a three-part construction:

1. Detector head (fixed temp or rate of rise)
2. Wireless address module
3. Ceiling mount

The detector shall be analogue addressable.

The wireless address module shall have the ability to use UHF 868 MHz frequency transmitter/receivers.

The wireless address module shall house a battery compartment, providing primary and secondary supply support and a microprocessor control unit. The battery pack should be capable of powering the device for five years under normal conditions.

The detector head should operate at 3 volts.

The wireless address module shall contain a factory programmed unique ident code.

The unit shall be fitted with an integral tamper switch, which makes contact with the ceiling mount and also be capable of monitoring detector head removal.

The unit shall be capable of indicating low battery warning with a minimum of thirty days' notice of impending failure.

The unit will transmit its battery condition indicating when the batteries require replacement.

The device shall have non-volatile memory.

The device shall be capable of being logged on to a Gateway and addressed via the Wireless Hub.

The device shall be third party certified and tested to EN54 parts 5 and 25.

Analogue Addressable Multi-Sensor Detector

All detector assemblies used shall be of a three-part construction:

1. Detector head
2. Wireless address module
3. Ceiling mount

The detector shall be self-testing and be analogue addressable.

The wireless address module shall have the ability to use UHF 868 MHz frequency transmitter/receivers.

The wireless address module shall house a battery compartment, providing primary and secondary supply support and a microprocessor control unit. The battery pack should be capable of powering the device for five years under normal conditions.

The wireless address module shall contain a factory programmed unique ident code.

The unit shall be fitted with an integral tamper switch, which makes contact with the ceiling mount and also be capable of monitoring detector head removal.

The unit shall be capable of indicating low battery warning with a minimum of thirty days' notice of impending failure.

The unit will transmit its battery condition indicating when the batteries require replacement.

The device shall have non-volatile memory.

The device shall be capable of being logged on to a Gateway and addressed via the Wireless Hub.

The device shall be third party certified as tested to EN54 parts 5, 7 and 25.

Callpoint

Callpoints or break glasses are to be of such manufacture as generally used within the fire industry.

The wireless module shall have the ability to use UHF 868 MHz frequency transmitter/receivers.

The unit shall be fitted with an integral tamper switch that shall make contact with the back box.

The callpoint shall house a battery compartment, providing primary and secondary supply support and a microprocessor control unit. The battery pack should be capable of powering the device for five years under normal conditions

The callpoint shall have its own unique ident code installed during manufacture.

The unit shall be capable of indicating low battery warning with a minimum of thirty days' notice of impending failure.

The unit will transmit its battery pack condition indicating when a replacement is due.

The device shall have non-volatile memory.

The device shall be capable of being logged on to a Gateway and addressed via the wireless Hub

The device shall be third party certified as tested to EN54 parts 11 and 25.

Addressable Wireless Input/Output Transmitter

The unit shall be fitted with an integral tamper switch.

The wireless module shall have the ability to use UHF 868 MHz frequency transmitter/receivers.

The wireless input/output transmitter shall house a battery compartment, providing primary and secondary supply support and a microprocessor control unit. The battery pack should be capable of powering the device for five years under normal conditions.

The unit shall provide the facility of transmitting alarm signals from third party equipment, such as beam detection, aspirating detection systems and other ancillary equipment or fire related systems that require monitoring by the fire control panel. The Input shall be fully monitored.

The unit shall provide the facility of receiving command signals from the control panel to devices that require remote activation, including magnetic door release units, staircase ventilation systems or other ancillary equipment.

The unit shall provide the facility of a fail-safe mode for the output operation.

The unit shall provide a variant with dual input and dual output facility.

The unit shall have an interface for a 230V AC switching output module.

The unit shall be capable of indicating low battery warning with a minimum of thirty days' notice of impending failure.

The unit will transmit its battery pack condition indicating when the batteries require replacement.

The device shall have non-volatile memory.

The device shall be capable of being logged on to a Gateway and addressed via the wireless Hub.

The device shall be third party certified as tested to EN54 parts 18 and 25.

Electronic Sounder & Visual Alarm Device

Sounders are to be of such manufacture as generally used within the fire industry.

The unit shall be capable of generating different sounder tones set via the sounder and have the ability to adjust the volume via a potentiometer.

The wireless sounder shall have batteries providing primary and secondary supply support and a microprocessor control unit. The battery pack should be capable of powering the device for five years under normal conditions.

The unit shall have an in-built microphone allowing for a rapid and unobstructed test of every sounder, generated and reporting to the control panel.

The wireless module shall have the ability to use UHF 868 MHz frequency transmitter/receivers.

The unit shall be fitted with an integral tamper switch which makes contact with the wall mount and also be capable of monitoring sounder head removal.

The unit shall be capable of indicating low battery warning with a minimum of thirty days' notice of impending failure and provision to energise the sounder at its full operating level for a further thirty-minute period.

The unit will transmit its battery pack condition indicating when a replacement is due.

The device shall have non-volatile memory.

The device shall be capable of being logged on to a Gateway and addressed via the wireless Hub.

VAD's should meet the wall or ceiling class category appropriate to room size and mounting heights

The device shall be certified as tested to EN54 parts 3, 23 and 25.

Combined Detector Sounder/Visual Indicator

The unit shall be capable of generating different sounder tones set via the sounder and have the ability to adjust the volume.

The wireless sounder/beacon base shall have batteries providing primary and secondary supply support and a microprocessor control unit. The battery pack should be capable of powering the device for five years under normal conditions.

The unit shall have an in-built microphone allowing for a rapid and unobstructed test of every sounder, generated and reporting to the control panel.

The wireless module shall have the ability to use UHF 868 MHz frequency transmitter/receivers.

The unit shall be fitted with an integral tamper switch, which makes contact with the ceiling mount and also be capable of monitoring sounder/head removal.

The unit shall be capable of indicating low battery warning with a minimum of thirty days' notice of impending failure and provision to energise the sounder at its full operating level for a further thirty-minute period.

The unit will transmit its battery pack condition indicating when a replacement is due.

The device shall have non-volatile memory.

The device shall be capable of being logged on to a Gateway and addressed via the wireless Hub.

The device shall be certified as tested to EN54 parts 3, 5, 7 and 25.

Visual Alarm Device

Visual Alarm Devices (VAD) are to be of such manufacture as generally used within the fire industry.

The wireless VAD shall have batteries providing primary and secondary supply support and a microprocessor control unit. The battery pack should be capable of powering the device for five years under normal conditions.

The wireless module shall have the ability to use UHF 868 MHz frequency transmitter/receivers.

The unit shall be fitted with an integral tamper switch which makes contact with the wall mount and also be capable of monitoring VAD head removal.

The unit shall be capable of indicating low battery warning with a minimum of thirty days' notice of impending failure and provision to energise the sounder at its full operating level for a further thirty-minute period.

The unit will transmit its battery pack condition indicating when a replacement is due.

The device shall have non-volatile memory.

The device shall be capable of being logged on to a Gateway and addressed via the wireless Hub.

VAD's should meet the wall or ceiling class category appropriate to room size and mounting heights

The device shall be certified as tested to EN54 parts 23 and 25.

Wireless Door Controller

The wireless door controller should meet the requirements of BS:7273 Part 4 Code of practice for the operation of fire protection measures. Actuation of release mechanisms for doors

The device will operate and control the release of door upon the activation of an alarm via the CIE and fire system devices.

The door controller will take an address from the system and operate as a device on the system with full addressability and reporting at the CIE.

Wireless Fire Detection System Design

The company providing the tender shall submit all relevant information and detail as required for the appropriate design of the fire protection system as governed by the requirements below.

The detection system shall be arranged to comply with the requirements of BS5839 part 1:2017 and ensure optimum efficiency of smoke detection coverage commensurate with aesthetics and practical constraints.

Prior to installation the nominated contractor shall submit working drawings with engineering design details endorsed by the manufacturer.

The system shall be commissioned by the manufacturer's approved installer who is suitably trained to survey, install, commission and maintain the system during its lifetime.

The system and all of its sensors/devices shall be manufactured by a company working and accredited to the disciplined requirements of the ISO9001 Quality System.

All system components shall have relevant third-party certification.

Training

General

The Fire Alarm contractor shall provide the client with details of the training required by personnel to operate and maintain the fire detection and alarm system.

The Fire Alarm contractor shall provide two levels of training:

- System Training
- Other Staff Training

The Fire Alarm contractor and the client shall jointly agree the number of staff to attend the training courses.

Other Staff Training

Other staff training shall include training sessions provided on-site after hand over of the system.

The training sessions shall be given by an experienced and competent engineer familiar with the fire system installed.

The scope of training provided shall include full operating instructions in the use of the fire system. This shall include instruction in the procedures to be followed in the event of fire and false alarms.

Maintenance

General

In accordance with recommendations in BS 5839–1:2002 fire systems should be regularly maintained under a maintenance agreement.

Fire and planning authorities, and in certain cases insurers, have powers to check that fire systems are maintained. Failure to maintain the fire detection and alarm system could contribute to death or injury in the event of fire. It is a requirement of the Fire Safety Order that all fire detection and alarm systems are regularly maintained.

The client shall be responsible for ensuring that daily, weekly and monthly routine maintenance is carried out in accordance with the recommendations set out in BS 5839–1 and the service and maintenance instructions provided by the Fire Alarm contractor or manufacturer.

The Fire Alarm contractor shall provide detailed information about the maintenance services which can be provided after hand over of the system.

If requested, the Fire Alarm contractor shall prepare and submit a draft maintenance contract for consideration by the client.

The draft contract shall include complete details of all materials and labour required to maintain the system in correct working order. It shall also include details of the testing procedures which will be carried out and specify the proposed number of visits per year.

The Fire Alarm contractor shall be able to offer a 24-hour 365-day service call-out facility.

For More Information

This document has been produced to assist in the collation of a fire alarm detection system specification with wireless or hybrid components for tender and quotation purposes.

All elements contained within are free to use as required and can be reproduced and copied without further permission.

EMS is also able to provide FREE certified CPD seminars on a number of subjects associated with wireless and hybrid fire detection systems as well a fire system related subject.

For course details and availability or for any further information please contact:

Ray Puttock – Commercial Support Manager

EMS Ltd
Sea Street
Herne Bay
Kent CT6 8JZ

01227 369570

ray.puttock@carrier.com