

FireCell

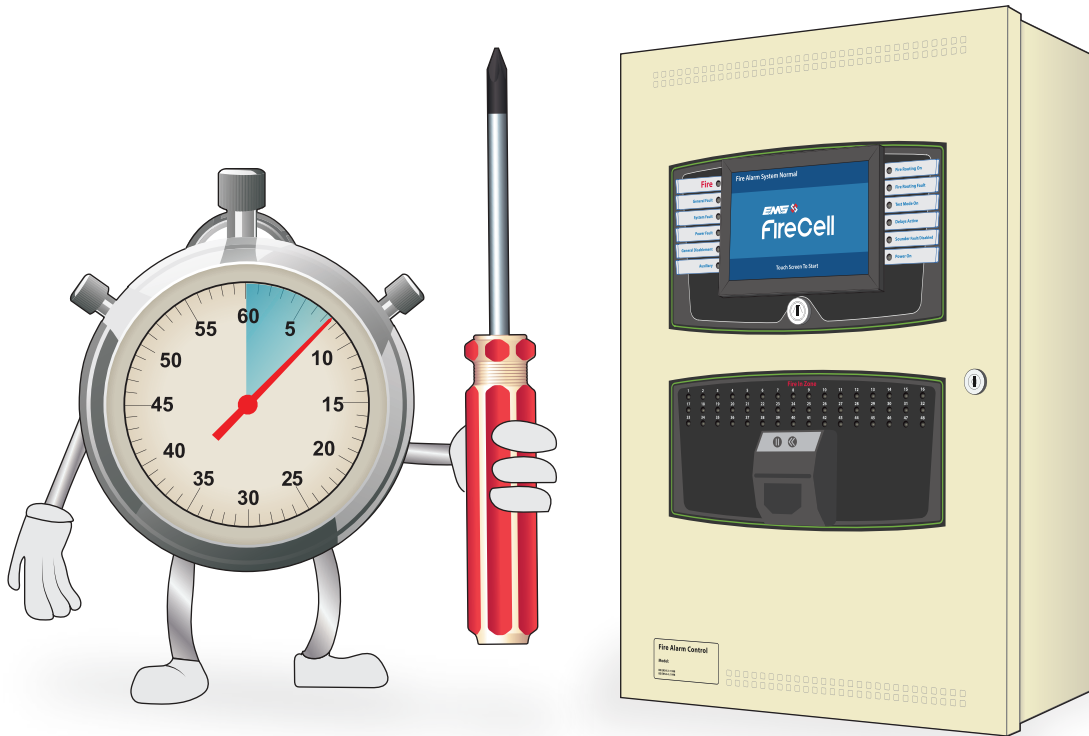

Taktis

QUICK START GUIDE



MK254 FireCell Taktis® Quick Start Guide Issue 3
www.emsgroup.co.uk



Taktis® introduction

The Taktis range of fire detection control panels are compatible with the EMS FireCell system and EMS Fusion Radio Loop Module (RLM). All installation guidelines are the same as when fitting an EMS Syncro AS panel, although panel operation will vary.

Programmed or unprogrammed system?

This guide covers the installation of both programmed and unprogrammed systems.

DO NOT press the device logon buttons if the system is supplied pre-programmed.



Doing this will unprogramme the device from the system.

More detailed manuals have been supplied in the FireCell Instruction Pack within the control panel packaging.

Programming can be achieved either **manually** or via **computer programs**.

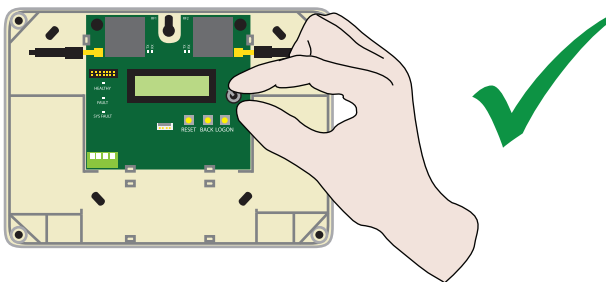

Manual device programming on the Taktis panel

Program the Control Panel; ensuring Loop number and addresses programmed at the Radio Hub correspond to that programmed at the Control Panel.

With the write switch enabled and the control key switch in the enabled position;

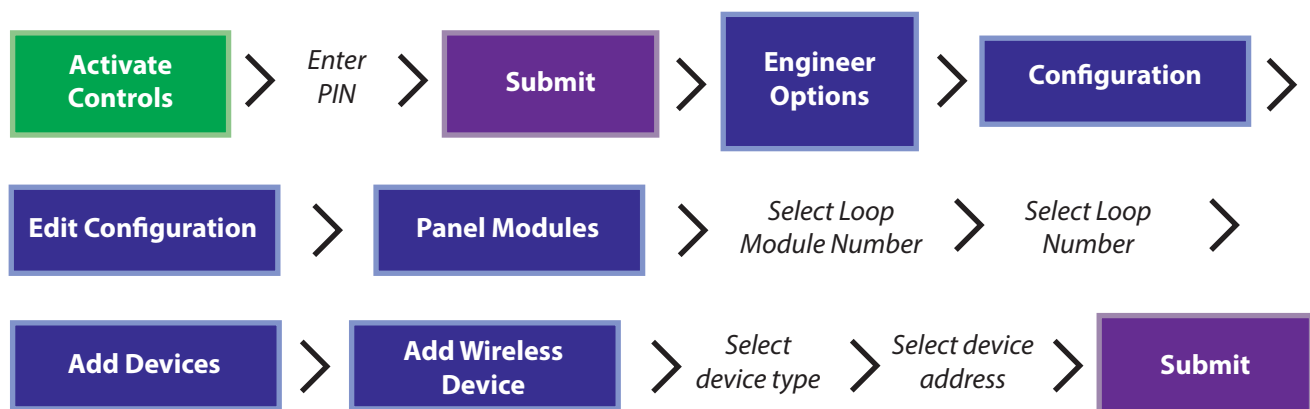

FireCell on Taktis - Radio Hub location recap

The Radio Hub is powered from the Control Panel's loop connection.

For optimum wireless performance, the following must be observed:

- Ensure the Control Panel and Radio Hub are installed as per the site survey.
- Ensure the Radio Hub is not installed within 2m of other wireless or electrical equipment (not including the Control Panel).
- Ensure the Radio Hub is not installed within 0.6m of metal work.

NEVER SITE THE HUB NEAR METAL WORK OR ELECTRICAL EQUIPMENT

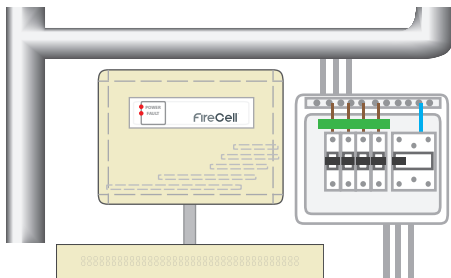

600mm AWAY FROM METAL *

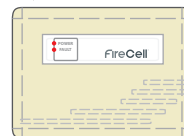

2m AWAY FROM OTHER ELECTRICAL EQUIPMENT

WITHIN 10m

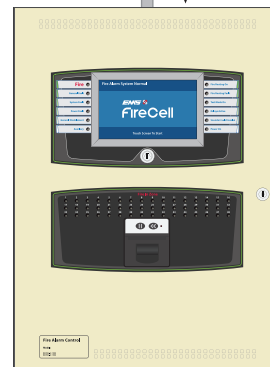

* 300mm is an acceptable distance where 600mm is not achievable

NEVER SITE THE HUB BELOW OR TO THE SIDE OF THE PANEL

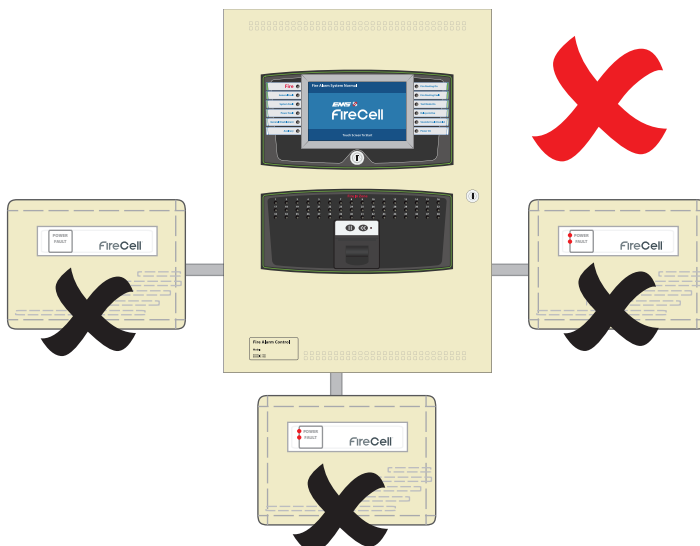

HUB CORRECTLY SITED ABOVE THE PANEL

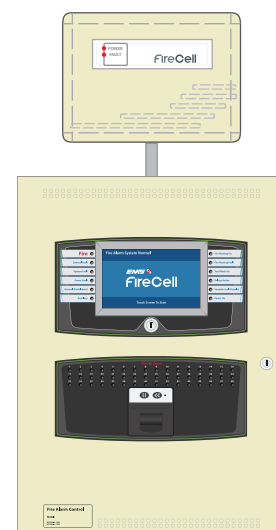

FireCell Radio Hub to Taktis - wiring connections

The Radio Hub has up to four separate sets of loop connections: LOOP IN -, LOOP IN +, LOOP OUT - and LOOP OUT + for each available loop. The cable must be passed through the entry points provided. Connections are detailed below:

| LOOP 1 | |
|--------|---------|
| PANEL | HUB |
| OUT + | → IN + |
| OUT - | → IN - |
| IN + | → OUT + |
| IN - | → OUT - |

NOTE: Repeat for loops 2-4 if used

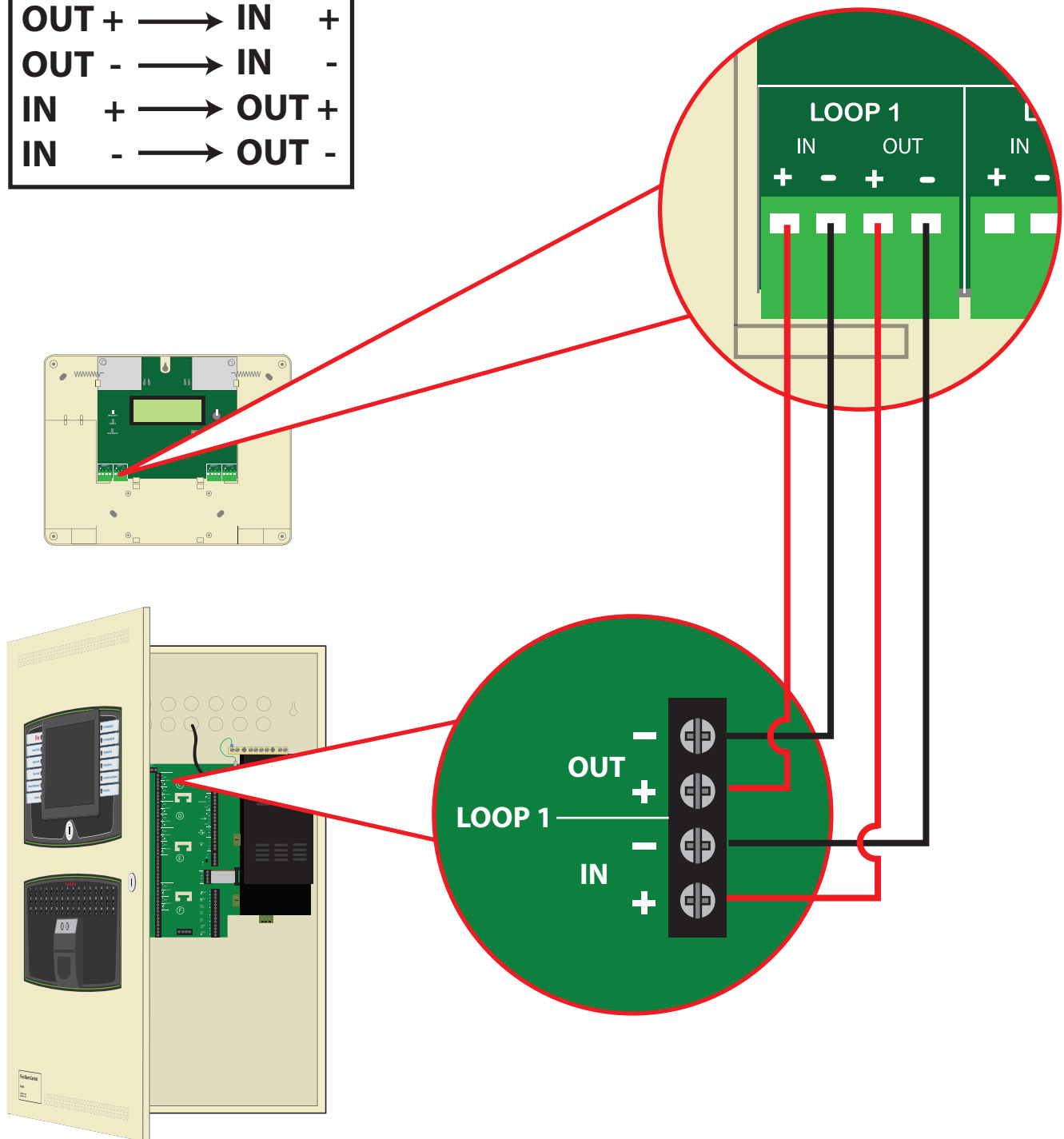

Fusion RLMs on Taktis - RLM location recap

Radio Loop Modules (RLMs) are powered from the Control Panel's loop connection.

For optimum wireless performance, the following must be observed:

- Ensure RLMs are installed as per the site survey
- Ensure the Loop Module is not installed within 2m of other wireless or electrical equipment (not including the Control Panel).
- Ensure the Loop Module is not installed within 0.6m of metal work.

**NEVER SITE AN RLM
NEAR METAL WORK OR
ELECTRICAL EQUIPMENT**

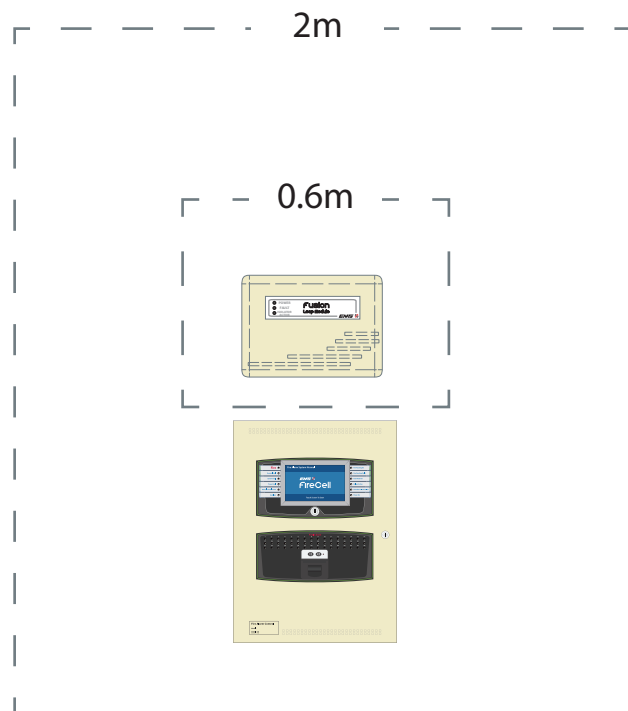
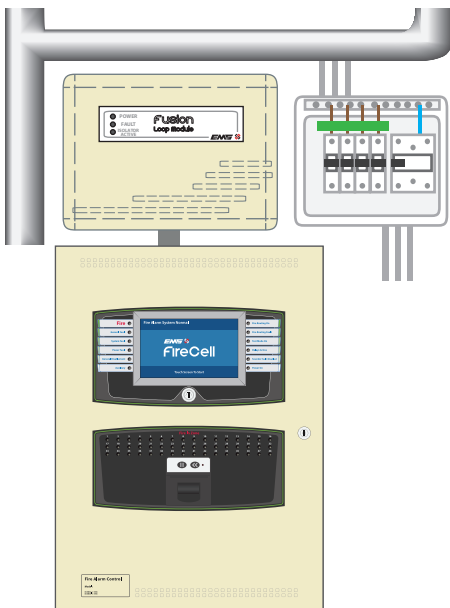

Fusion RLMs on Taktis - wiring connections

Each RLM has connections: LOOP IN -, LOOP IN +, LOOP OUT -, LOOP OUT + and 2x screen connections. The cable must be passed through the entry points provided. Connections are detailed below:

Single RLM

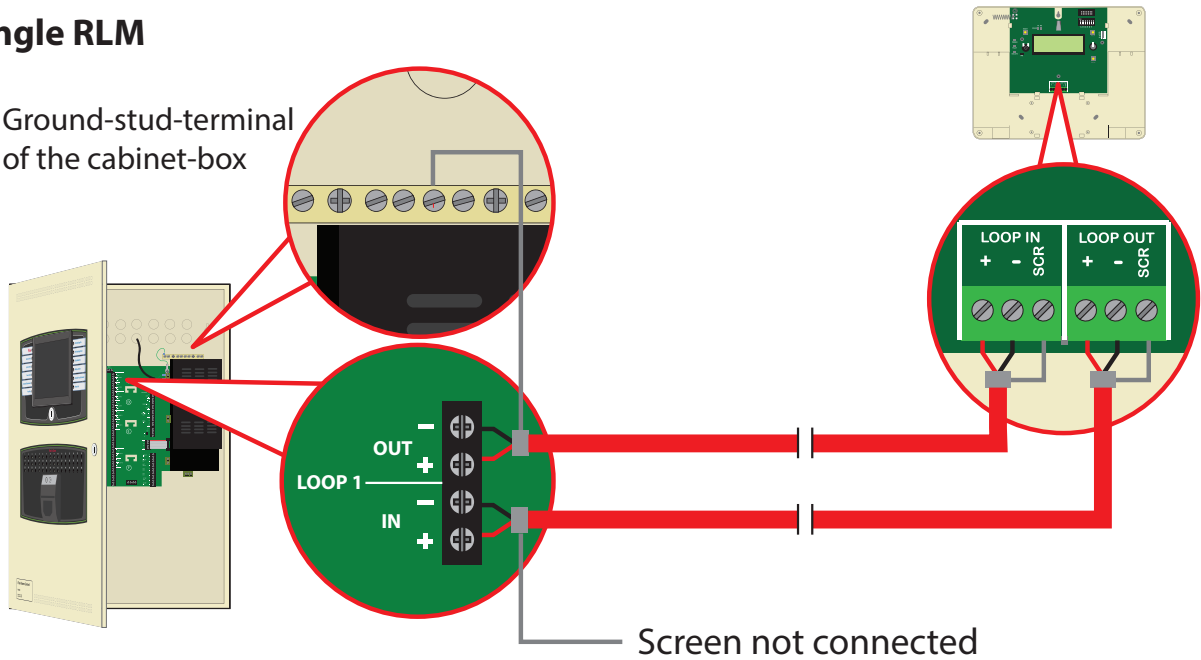

Ground-stud-terminal of the cabinet-box

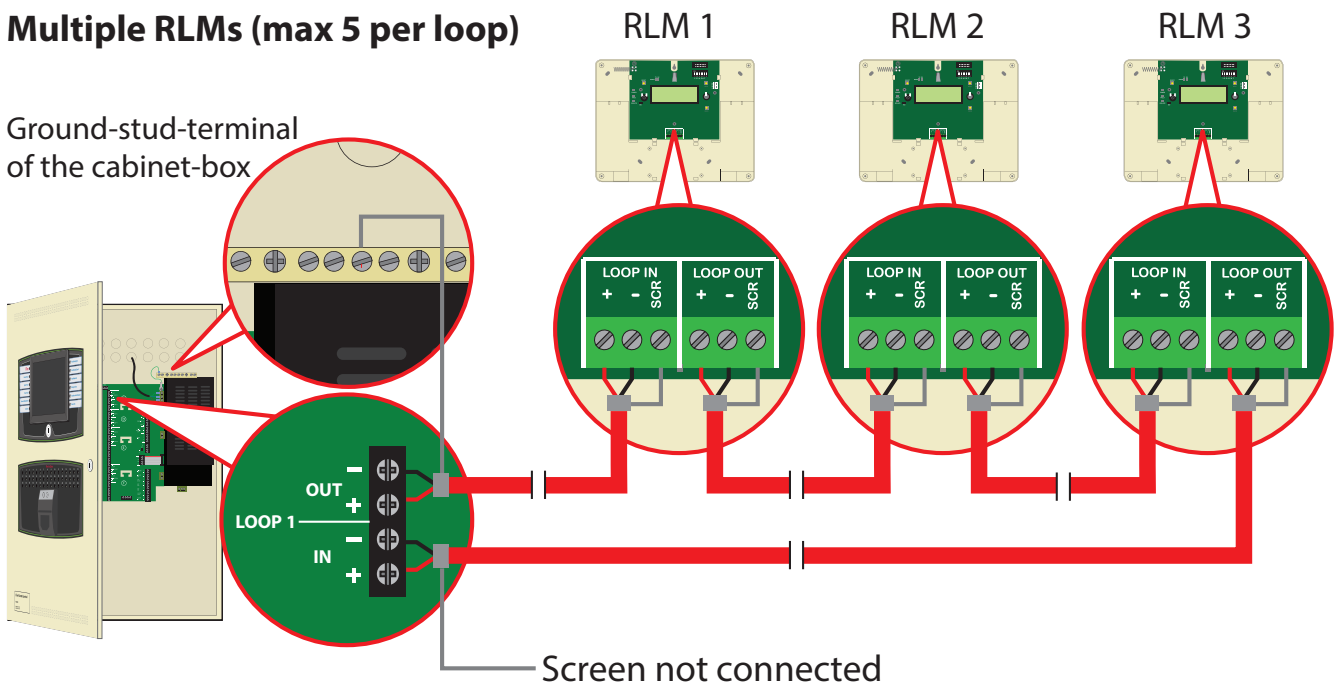

Multiple RLMs (max 5 per loop)

Ground-stud-terminal of the cabinet-box



-  www.emsgroup.co.uk
-  +44 (0) 1227 369570
-  ems.customerservices@carrier.com



Fire Industry Association



Intertek



The information contained within this literature is correct at time of publishing. EMS reserves the right to change any information regarding products as part of its continual development enhancing new technology and reliability. EMS advises that any product literature issue numbers are checked with its head office prior to any formal specification being written.